



**Ballan garage doors:**  
design, technology and safety





**MyFusion 400 up-and-over door with Sikura HF structure, sandgrain finish similar to Ral 7016 colour. The edge covers and handle art. 98 are optional.**



## Ballan garage doors: lots of models with countless customisation options

Counterweight up-and-over doors and sectional doors with outstanding characteristics: energy efficient, durable, safe, technological, available in a variety of models also offering optimal thermal efficiency.

Doors in galvanised steel, wood, with insulated panels, painted, coated, manual or power-operated, equipped with patented technological solutions and enhanced with a wide range of optional accessories.



**MyFusion counterweight up-and-over doors** 8  
Outstanding quality finally accessible to all.

**Linealegno HF counterweight up-and-over doors** 20  
The prestige of thermal efficiency

**Steel counterweight up-and-over doors** 28  
Hardened steel, absolute reliability

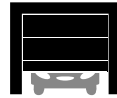

**New Age XT sectional doors** 44  
Superior style not afraid of imitations

**Onda sectional doors** 54  
A perfect barrier to insulate the garage



**Flexa lateral sliding doors** 68  
Perfect closure even in difficult situations



**excellence in doors**

## Ballan SpA believes in quality

This is proven by the fact that it was the first in its field to achieve EN ISO 9001 certification!

But even more so are the garage door production plants, located in the manufacturing facilities of Villa del Conte and Tombolo (Padua) Italy. All absolutely state-of-the-art.

This is where all stages of production take place, ranging from profiling the steel parts to the batch construction of insulated panels and the painting of the garage doors.

A production process that surely relies on cutting-edge systems and technologies, but cannot ignore the expertise and experience of its highly qualified personnel: the starting point of Ballan's quality.

## Ballan SpA an environmentally aware company

A company that pursues a policy of respect for the planet and reduction of energy usage.

And that invests massive resources in R&D, training, and upgrading its production plant and storage facilities.



A company that aims for excellence



## Durability, shape retention, reliability, safety, elegance, overall dimensions...

You can demand everything from Ballan garage doors. And you can especially expect them to adapt perfectly to your garage, to the size of its entrance and to the way it will be used. It's all thanks to the various solutions applied by Ballan to make its doors... universal!



## Design and production "Made in Ballan"

The exceptional performance and absolute reliability of the garage doors and of the operators are 100% guaranteed. Ballan's garage doors are built with 100% compliance with UNI EN 13241-1 and all the European directives on occupational safety. They are provided with CE Marking, Declaration of Performance and for power-operated doors, also a CE Declaration of Conformity.



## Safety is a priority

Remote opening of your garage door is ultra-convenient. Thanks to Ballan, this simple action is also the safest choice, because all our operators are governed by electronic control systems. Our control systems guarantee unparalleled operational efficiency, and are designed to reverse the direction of movement instantly in the presence of obstacles.



## Ballan SpA has big plans for the coming years

In fact it is researching construction solutions which will reduce the overall dimensions of its doors. It is testing new materials for the cladding panels to improve energy savings, always with a view to environmental sustainability. And of course there is the research on new models and the design even more efficient and safe operators. For Ballan, excellence is a daily challenge. A challenge taken up almost 50 years ago.



## Up-and-over doors: safety



### Technical performance

The manufacturer states in the Declaration of Performance (DoP) the values required by the Product Standard, after they have been certified by a notified body. In this way, based on the DoP, the buyer can assess and compare the quality of the garage door.



**Declaration of Performance (DoP)**, which describes the characteristics of the product in compliance with CPR 305/2011.



**CE Declaration of Conformity**, which certifies the respect of all European standards in force for power-operated doors.



**Installation, Use and Maintenance Handbook**: an easy-to-consult guide that provides all the necessary information.

## Complete safety according to the CPR 305/2011 and compliance with the EN 13241-1 Product Standard

All garage doors must comply with a set of legal provisions aimed at protecting the personal safety of those who use them. The manufacturer, to declare the performance of the product as required by the Regulation Construction Products CPR 305/2011, shall submit the door from the garage to initial tests of the type with a notified body in accordance with the product standard EN 13241-1: resistance to wind load, security openings, operation force for the power-operated doors. Doors must bear the CE marking and be supplied with a Declaration of Performance (DoP), while power-operated doors must be supplied also with a CE Declaration of Conformity in compliance with the Machinery Directive.

### **Manual up-and-over doors:** (ready for operator fitting)

- Cable break device to prevent the door leaf from dropping accidentally;
  - 25 mm safety clearances between the lever mechanisms;
  - perimeter seal between door leaf and fixed frame;
  - anti-shear lever arms;
  - self-centring brackets to ensure correct closing of the leaf.
- They bear the CE marking and come with a Declaration of Performance (DoP).

### **Up-and-over doors with operators:**

- Cable break device to prevent the door leaf from dropping accidentally;
  - 25 mm safety clearances between the lever mechanisms;
  - perimeter seal between door leaf and fixed frame;
  - anti-shear lever arms and motor arms;
  - self-centring brackets to ensure correct closing of the leaf;
  - guards of moving parts;
  - motors equipped with force limiter device;
  - presence detectors (photocells).
- They bear the CE marking and come with a Declaration of Performance (DoP) and CE Declaration of Conformity.

To prevent the risk of crushing fingers, safety is provided by a 25 mm clearance between the fixed part and the door leaf and protected by rubber side seals.



**CE**



CE marking product identification data plate stating all the data required by current regulations.



Anti-fall protection device incorporated in the tracks engages in the event of cable breakage, preventing the door leaf from dropping.

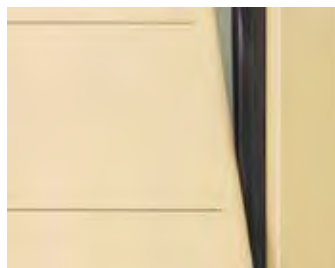

Safety clearance of 25 mm between fixed and mobile parts with the rubber side seals that are an additional protection element.



Presence detectors, applied on the side jambs, instantly block door operation in the event of transit of persons or objects (optional).



# MyFusion up-and-over doors



- 1. External and internal steel sheet layers
- 2. High-density polyurethane foam (49 Kg/m<sup>3</sup>)
- 3. Upper profile in thermoplastic material.
- 4. Lower profile in thermoplastic material.

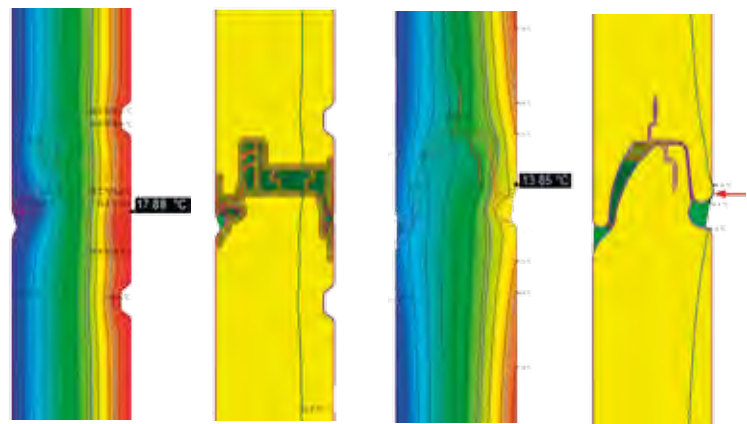

Ballan's thermoplastic joint

Standard panel joint

**Ballan's Research and Development Department worked on 3 points:**

- 1. Insulation of the structure.
- 2. Panel design Ballan.
- 3. Gaskets of thermoplastic material.

## Insulated panels: excellent Ballan technology

The MyFusion panelling is entirely Made in Ballan: each element is made individually in a press, all types of stucco or wood-effect of finishing of the plates, made of pre-painted galvanized steel, are designed and manufactured by Ballan. An original manufacturing system, designed by the company, ensures high geometric accuracy, a superior mechanical quality and perfectly flat panels.

Our 400 mm pitch panels, a unique characteristic of Ballan's panels, are 40 mm thick and stand out for their excellently styled finish; the use of thermoplastic joints contributes to their lightness and significantly to their excellent insulation. In addition, the 400 mm pitch panelling increases the structural strength of the door itself. An internal flame-retardant polyurethane foam core, totally HCFC-free completes the panel, as evidence of the company's respect for the environment.





## MyFusion, the up-and-over doors that all garages would like to have

Up-and-over doors for all sizes of garage, perfectly integrated in any environment.

This was the objective of the study that led Ballan's R&D department to design garage doors capable of ensuring maximum, class 3 certified strength, excellent thermal efficiency, and looks that are both outstanding and customisable with a broad range of finishes.

All this has been achieved with an industrial production process that minimises costs and makes it possible to keep all production entirely Made in Ballan, enriched by a new profiling machine for embossed wood finishing.



Watch the video of Ballan's panel production for MyFusion up-and-over doors

## Panels, totally designed and produced by Ballan

The sandwich panels are assembled individually by means of thermoplastic joints enabling not only an optimal smooth distribution of the polyurethane sealant, but also to thermally insulate the internal side from the external side.

The drawings shown compare the joining of MyFusion panels with that of the typical sandwich panels on the market. The effectiveness of Ballan's panel joining is shown by the isothermal curves of the chart and how the temperature is uniformly distributed near the panel joint as if the joint did not exist and the internal and external surfaces were separated. Instead, in the joint of a normal panel, under the same environmental conditions, the cold area extends farther inside and at the same point the internal temperature difference is significant and in the standard panel's junction, condensate begins to form even in common climatic conditions.



## ABS lower seal

The lower seal made of black ABS, is 50 mm high, with lateral sealing caps and an aluminium profile inside.

The appearance is exquisite. It ensures a perfect seal between the door leaf and the floor, contributing to the door's thermal performance.

## Thermal efficiency



MyFusion up-and-over garage doors with standard dimensions and fittings (e.g. L 3500 x H 2500 mm) have an indicative value of thermal transmittance of\*:

- 1.2 W/m<sup>2</sup>K surface mounted (SM)
- 1.8 W/m<sup>2</sup>K surface mounted, with pass door (SM+PD)

1.2  
SM

1.8  
SM+PD

## Class 3 wind load resistance



The company manufactures its garage doors following the reference standards as required by the Construction Products Regulation CPR 305/2011. The manufacturer must submit the garage door for initial testing to a Notified Body as per Product Standard EN 13241-1: wind load resistance (**in Class 3 for MyFusion doors**), opening safety and operating force for power-operated doors.

(\*) The stated thermal transmittance values are to be considered guideline only, and apply to standard surface mounted up-and-over doors ranging from 8 to 10 m<sup>2</sup>. Only on request at the time of ordering, Ballan SpA will issue a thermal transmittance declaration specific to the garage door requested.



## MyFusion up-and-over doors



MyFusion door, surface mounted.  
A detail of the rounded profile of the door leaf.  
This type of mount makes (optional) coverings unnecessary.

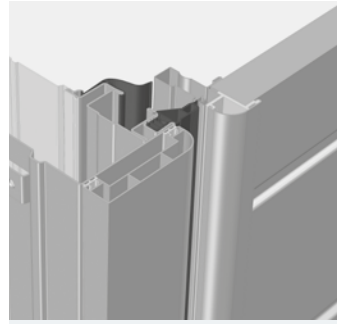

MyFusion door, flush mounted with the external wall, with coverings inserted on the front of the structure. A detail of the rounded profile of the door leaf and vertical covering. An eye-catching improvement in door aesthetics.

standard

The new rounded edge profiles of the door leaf are standard in all models.

optional

The new (optional) horizontal and vertical coverings are perfectly coplanar and cover the door structure, therefore they are specially recommended when the door is flush mounted.



rounded edges

Detail of MyFusion doors with Sikurtec HF structure.



horizontal and vertical coverings

Detail of MyFusion door with Sikurtec HF structure and coverings inserted on the front of the structure.

The rounded corners of the door leaf are a Ballan exclusive, standard on all MyFusion models.

With vertical and horizontal shaped covers (optional), the MyFusion up-and-over door looks outstanding because it is perfectly flush.

The covers are made of anodized aluminium painted the same colour and are mounted in front of the structure.

They are sized according to the Spazio HF, Sikurtec HF and Sikura HF structure, both manual and power-operated.

They are recommended if the door is flush mounted, especially if flush with the outer wall, since they are perfectly flush with the door leaf.

When surface mounted, since the structure is hidden by the masonry, the covers are not necessary.







MyFusion up-and-over doors:  
rounded edges for excellent looks

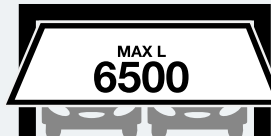

MyFusion 400 up-and-over door, Sikurtec HF structure. The edge covers, the Ral 1014 colour and handle art. 98 are optional.

### The three structures for MyFusion

(unit of measurement 10 mm)

STRUCTURE SPAZIO HF	STRUCTURE SIKURTEC HF	STRUCTURE SIKURA HF
		
from L 2000 to 3000 from H 2000 to 2650	from L 2000 to 3500 from H 2000 to 2650	from L 2000 to 6500 from H 2000 to 3000
<b>AUTOMATION</b> 	<b>AUTOMATION</b> 	<b>AUTOMATION</b> 



**ABS in black lower seal**, H 50 mm, with lateral sealing caps and aluminium profile inside. It ensures a perfect seal between the door leaf and the floor, with a stylish look.  
Standard with Sikurtec HF and Sikura HF structures, optional for Spazio HF structures.

### MyFusion, the up-and-over doors that all garages can afford

A panelling that fits in any size of grange, since the 3 exclusive structures optimise space and overall dimensions.  
The safe and quiet operators, adapted to the structure, are entirely designed by the company and guarantee the best possible operating efficiency.



# MyFusion up-and-over doors



External view of MyFusion 400 up-and-over door, Sikurtec HF structure, embossed wood finish. The similar to Ral 9016 colour is standard, the operator and the handle art. 98 are optional.



External view of MyFusion 200 up-and-over door, Sikura HF structure, embossed stucco finish. The Ral 6019 colour, the operator and handle art. 98 are optional.



External view of MyFusion Box up-and-over door, Sikura HF structure, embossed stucco finish. The similar to Ral 9016 colour is standard. The inspection windows, the operator and the handle art. 98 are optional.

## MyFUSION 400

MyFusion 400 is the up-and-over door with rounded edges and excellent technical features: strength, durability, safety and optimal heat and acoustic insulation thanks to its exclusive insulated panels that are 400 mm high and 40 mm thick.

Available in several external surface finish versions, embossed stucco, embossed wood, smooth and sandgrain.

City structure also available with slide-away door leaf.



## MyFUSION 200

MyFusion 200, with additional horizontal ribbing on the outside of its panels, is the up-and-over door with rounded edges and excellent technical features: strength, durability, safety and optimal heat and acoustic insulation thanks to its exclusive insulated panels that are 400 mm high and 40 mm thick.

Available in several external surface finish versions, embossed stucco, embossed wood, smooth and sandgrain.

City structure also available with slide-away door leaf.



## MyFUSION BOX

MyFusion Box, in georgian style, is the up-and-over door with rounded edges and excellent technical features: strength, durability, safety and optimal heat and acoustic insulation thanks to its exclusive insulated panels that are 400 mm high and 40 mm thick.

Available in two external surface finish versions, embossed stucco and embossed wood.

City structure also available with slide-away door leaf.





MyFusion 400 up-and-over door, sandgrain finish similar to Ral 7016. Edge covers and handle art. 78 are optional.

## External surfaces for MyFusion panel



External panel with embossed stucco finish, embossed wood, smooth, standard in white similar to Ral 9016.

Not all finishes are available for all models.

Internal side embossed stucco finish standard in white similar to Ral 9016.

External panel with sand grain finish, pre-painted in similar to Ral 7016. Internal side of panels with embossed stucco finish in white similar to Ral 9016 (structure in Ral 7016).



Internal side embossed stucco finish standard in white similar to Ral 9016.

## Many colour shades

The embossed stucco, embossed wood and smooth finishes of the MyFusion up-and-over doors standard on the outside and inside are pre-painted white similar to Ral 9016 and all parts are painted white Ral 9016.

As an option the finishes can be painted inside and out in any colour from the Ballan Ral colour chart on request, for a choice of over 200 finishes! Or even in Ballan's new mica-based colours.



MyFusion 200 up-and-over door with Space HF structure, embossed stucco finish. The edge covers, the similar to Ral 1015 colour, the Profil pass door and handle art. 98 are optional.

N.B.:  
The presence of slight ripples in the smooth insulated panels is to be considered normal and not a defect. It is advisable to avoid the dark coloured panels for doors exposed to the sun, since the elements may flex and limit operation of the garage door.



## MyFusion up-and-over doors



MyFusion Viva 200 up-and-over door, smooth finish, super-polyester varnish light walnut wood-effect. Edge covers and handle art. 79 are optional.



External view of up-and over door MyFusion Viva 400, Spazio HF structure, embossed wood finish. External side of panels with wood-effect light walnut super-polyester varnish, and frame with standard Ral 8003 finish. The panel interior has an embossed stucco finish in white similar to Ral 9016. Handle art. 98 is optional.



External view of up-and over door MyFusion Viva 200, Spazio HF structure, embossed wood finish. External side of panels with wood-effect light walnut super-polyester varnish, and frame with standard Ral 8003 finish. The panel interior has an embossed stucco finish in white similar to Ral 9016. Handle art. 98 is optional.



External view of up-and over door MyFusion Viva Box, Spazio HF structure, embossed wood finish. External side of panels with wood-effect light walnut super-polyester varnish, and frame with standard Ral 8003 finish. The panel interior has an embossed stucco finish in white similar to Ral 9016.

### MyFUSION VIVA 400

MyFusion 400 is the up-and-over door with rounded edges and excellent technical features: strength, durability, safety and optimal heat and acoustic insulation thanks to its exclusive insulated panels that are 400 mm high and 40 mm thick.

Panels treated externally with wood-effect super-polyester varnish, in two variants of the external surface finish: embossed wood and smooth. Internal side of panels embossed stucco finish in white similar to Ral 9016. City structure also available with slide-away door leaf.



### MyFUSION VIVA 200

MyFusion Viva 200, with a central groove on the outside of its panels, is the up-and-over door with rounded edges and excellent technical features: strength, durability, safety and optimal heat and acoustic insulation thanks to its exclusive insulated panels height 400 mm and thickness 40 mm.

Panels treated externally with wood-effect super-polyester varnish, in two variants of the external surface finish: embossed wood and smooth. Internal side of panels embossed stucco finish in white similar to Ral 9016. City structure also available with slide-away door leaf.



### MyFUSION VIVA BOX

MyFusion Viva Box, in georgian style, is the up-and-over door with rounded edges and excellent technical features: strength, durability, safety and optimal heat and acoustic insulation thanks to its exclusive insulated panels height 400 mm and thickness 40 mm.

Panels treated externally with wood-effect super-polyester varnish, in the external surface finish: embossed wood. Internal side of panels embossed stucco finish in white similar to Ral 9016. City structure also available with slide-away door leaf.





## Wood-effect timeless elegance

The wood-effect super-polyester varnish provides a completely faithful reproduction of the appearance and unevenness of precious wood. Unlike real wood, this material is highly weatherproof and does not require constant care and maintenance.

### Finishes for the MyFusion Viva panel.



Internal side embossed stucco finish standard in white similar to Ral 9016.

External panel with embossed wood or smooth finish with wood-effect super-polyester varnish, available in two colours:  
 - Light walnut shade (structure in Ral 8003)  
 - Dark walnut shade (structure in Ral 8011).

Panel interior with embossed stucco finish in white similar to RAL 9016.

They can optionally be painted with wood-effect super-polyester varnish finish, smooth only.



MyFusion Viva 200 up-and-over garage door, "wood-effect" super durable polyester coating light walnut colour and embossed wood finish. Handle art. 79 is optional.

### STANDARD Internal side finish standard in white similar to Ral 9016.



As standard internal side of panels embossed stucco finish in white similar to RAL 9016 (frame painted with RAL 8003 or 8011).

In the photograph: internal view of My Fusion Viva 200/400/Box up-and-over door, Spazio HF structure painted with Ral 8003, the SIM-2 operator and handle art. 98 are optional.

### OPTIONAL As an option the panels can also be treated internally with wood-effect super-polyester varnish



As an option (for all three structures) the panels can also be treated internally with light walnut or dark walnut wood-effect super-polyester varnish as the outside (internal finishing is always smooth).

In the photo: internal view of up-and-over door MyFusion Viva 200/400/Box, Sikura HF structure, and counterweight sleeves are made of sheet metal pre-painted white similar to Ral 9016, the wood-effect internal painting, the ISY operator and handle art. 98 are optional.

N.B.:  
The presence of slight ripples in the smooth insulated panels is to be considered normal and not a defect. It is advisable to avoid the dark coloured panels for doors exposed to the sun, since the elements may flex and limit operation of the garage door.



## MyFusion up-and-over doors: optional



MyFusion 200 up-and-over door, Spazio HF structure, embossed stucco finish. Painted Ral 1015, Profil pass door and handle art. 96 are optional.



MyFusion Rare 400 up-and-over door with Sikura HF structure, embossed stucco finish. Painted Ral 7001 and Planus pass door are optional.



Detail of the lower threshold made of galvanized steel and painted the same colour.



Detail of the opening limiter installed in the upper part of the leaf.



Detail of the lock with aluminium handle and of the seal installed in the leaf of the pass door.

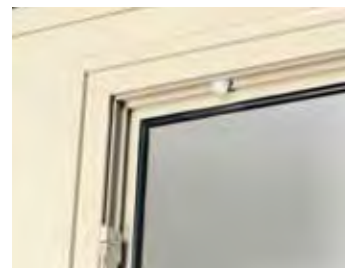

The electromagnetic safety sensor is installed in power-operated doors.



## PROFIL PASS DOOR



External view of the MyFusion 400 up-and-over door (Sikurtec HF structure) with Profil pass door (optional).

Details of Profil pass door: visible hinge and profiles.



## Profil pass door (optional)

The frame of the leaf of the Profil pass door and its counter-frame are built with aluminium profiles designed and manufactured by Ballan and painted the same colour as the panels (for MyFusion Viva models the profiles of the pass door are painted Ral 8003 or Ral 8011 colours). The lower threshold is made of galvanised steel painted the same colour, the lower threshold is 60 mm from the floor.

The pass door has a 750 mm wide passage, is equipped with three adjustable visible hinges, double closing seal (one on the leaf and one on the counter-frame), opening limiter installed on the upper part of the leaf, aluminium handle installed on the aluminium profile and lock with European cylinder.

The 3-point lock with security bolts is standard, while the drill-proof Defender safety cylinder is optional. An electromagnetic safety sensor is fitted on the power-operated doors.

## PLANUS PASS DOOR



External view of the MyFusion Rare 400 up-and-over door (Sikura HF structure) with Planus pass door (optional).

A detail of the flush profiles of the Planus pass door: the hinges are completely concealed.



## Planus pass door (optional): the door within the door, completely flush

The Planus pass door is flush with the door leaf and has concealed hinges.

The frame of the leaf of the pass door and counter-frame are made with aluminium profiles designed and manufactured by Ballan and painted the same colour as the panels (for MyFusion Viva models the profiles are painted with Ral 8003 or Ral 8011).

The lower threshold is made of galvanised steel painted in the same colour. The pass door has a 750 mm wide passage, is equipped with three concealed hinges, a double closing seal (one on the leaf and one on the counter-frame), opening limiter installed on the upper part of the leaf, aluminium handle installed inside the aluminium profile and lock with European cylinder (on request also with external handle).

The 3-point lock with security bolts is standard, while the drill-proof Defender safety cylinder is optional. An electromagnetic safety sensor is fitted on the power-operated doors.



### To increase burglary resistance, 3-point locks are standard on all pass doors

A 3-point lock is installed as standard in the pass door. The 3 security bolts positioned in the side hinges provide a high degree of protection against burglary attempts.



Detail of the security bolt: are inserted 3 bolts are mounted on the hinge side.

A 3-point lock is installed as standard in the pass door, while the drill-proof Defender safety cylinder is optional.





## MyFusion up-and-over doors: optional



### Fixed window frame in Alunox and PMMA glass

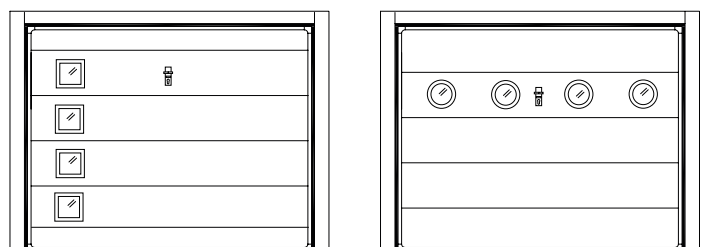

Fixed window frame in Alunox and PMMA glass, square 260x260 mm or round diameter 260 mm.



### Fixed window frame in Alunox and PMMA glass

Arc-shaped or rectangular fixed window frame in Alunox and PMMA (frosted acrylic) glass, with the possibility of modifying the quantity and position of the window according to the size of the door.

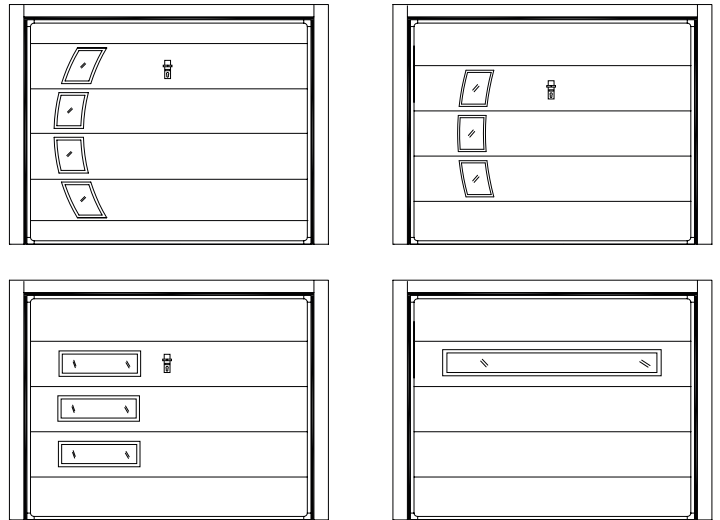

### Fixed windows frame painted the same colour

The rectangular windows with small frames are painted the same colour of the outer panelling. The tempered and anti-explosion glass is 380 x 190 mm, and is available with different types of glazing.

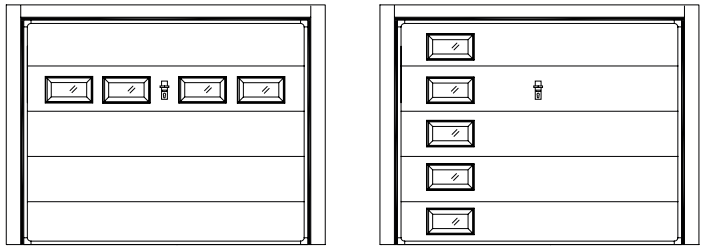

### Fixed windows with stainless steel frame

Rectangular windows with polished stainless steel frames. The tempered and anti-explosion glass is 380 x 190 mm, and is available with different types of glazing.

Many positions in the panels are possible for windows.

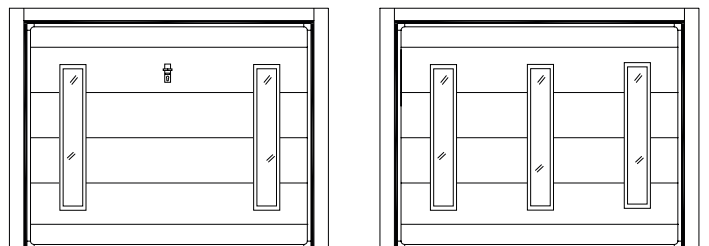

Vertical stainless steel windows. The window is L 180 mm x H 1300 mm, tempered and burglar-proof and can be selected.



### Rectangular windows with satin stainless steel frame

The window is L 180 mm x H 1300 mm, tempered and burglar-proof and can be selected with various frosting designs, also custom.

Art. 610 Art. 620 Art. 630 Art. 640



## Linealegno HF up-and-over doors



Linealegno HF up-and-over garage doors, mod. 500, clad with Okoumé multi-ply with an external cladding in bleached Oak and the insertion of a central stainless steel strip.



The best multi-ply wood, the largest selection of wood types and shades.

Unrivalled craftsmanship in woodworking, the result of great Ballan experience.

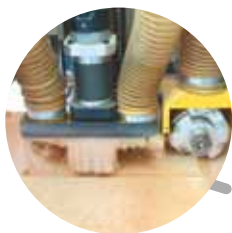

Lots of technological solutions, all innovative, to guarantee perfection in operation and accident protection.



A definitely superior construction quality, ensuring strength, durability and excellent heat insulation.



## Linealegno HF: the most prestigious up-and-over garage door

**The Linealegno HF counterweight up-and-over door is not only a perfect barrier against outdoor temperature changes, wind and rain. It is also the most durable, stylish and silent garage door.**

A great achievement leading to significant energy savings, thanks to the reduction in thermal bridges between the internal structure and the external wood sections, the overall thickness and the optimal distribution of the internal insulation material, as well as the perimeter seals and thermoplastic lower floor seal.

The frame of the door leaf and external structure, both in steel and wood clad, ensure remarkable stiffness, eliminating any creaking of wooden parts while maintaining a high degree of strength.

The panelling is made of multi-ply wood panels, more resistant to stress and deformation, kept in proper condition by the micro-ventilation provided by a small air jacket.

### Thermal efficiency



The Linealegno HF up-and-over garage doors with standard dimensions and fittings (e.g. L 3500 x H 2500 mm) have an indicative value of thermal transmittance of\*:

- 1.4 W/m<sup>2</sup>K surface mounted (SM)
- 1.6 W/m<sup>2</sup>K surface mounted, with pass door (SM+PD)

### The structure for Linealegno HF SIKURA HF

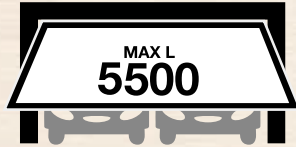

from L 2000 to 5500  
from H 2000 to 3000



## Follow the path of quality and safety

**1.4**  
SM

**1.6**  
SM+PD

(\*) The Linealegno HF up-and-over doors, with standard dimensions and fittings, obtain a thermal transmittance value of below 1.4 W/m<sup>2</sup>K, proven through testing with a notified body.

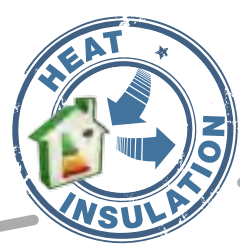

Linealegno HF up-and-over garage doors, with standard dimensions and fittings, obtain a thermal transmittance value of below 1.4 W/m<sup>2</sup>K, as proven through tests performed by a notified body.

Special fittings like the recessed die-cast aluminium handle designed by Ballan. The lock incorporates a drill-proof, tear-proof defender with safety cylinder.



The Ballan ISY operator mounted on the door leaf incorporates a motor, VISg control system with Gravity Accelerometer and command in a single unit, thereby ensuring excellent compactness.



The light and compact Smart remote control stands out for its innovative design and original black and white colouring.



## Linealegno HF up-and-over doors



The special Linealegno HF up-and-over garage doors, are clad with Okoumé multi-ply with an external cladding in dark Oak and the insertion of Corten-effect painted steel strips.



External view of Classique HF up-and-over door, oak colour 2.



External view of Elite HF up-and-over garage door, Douglas fir colour 1.



External view of Maxime HF up-and-over door, okoumé colour 1.

### CLASSIQUE HF

Classique HF model with vertical or horizontal slats (pitch 192 mm).  
Outer panel thickness 15 mm, available in multi-ply okoumé wood, or multi-ply okoumé with oak or Douglas fir cladding. Or in multi-ply knot-free larch, also brushed.  
Total thickness of door leaf: 105 mm.

### ELITE HF

Elite HF model with narrow vertical slats (pitch 94 mm).  
Outer panel thickness 15 mm, available in multi-ply okoumé wood, or multi-ply okoumé with oak or Douglas fir cladding. Or in multi-ply knot-free larch, also brushed.  
Total thickness of door leaf: 105 mm.

### MAXIME HF

Maxime HF model with herringbone slats (pitch 192 mm, angle 45°) pointing downwards.  
Outer panel thickness 15 mm, available in multi-ply okoumé wood, or multi-ply okoumé with oak or Douglas fir cladding. Or in multi-ply knot-free larch, also brushed.  
Total thickness of door leaf: 105 mm.



## The best multi-ply wood, the broadest selection of wood types and shades

The wood panels on the Linealegno HF counterweight up-and-over garage doors are manufactured with multi-ply okoumé or with multi-ply okoumé externally clad with top-quality precious wood types: oak and Douglas fir. Alternatively, they are available in knot-free larch multi-ply with an optional worn-effect brushed finish. A splendid range of solutions, for which Ballan ensures long life thanks to a special protective treatment, enhanced by the colourless varnish – strictly water-based – in six different colours.

Ral 3009

Ral 6005

Ral 6007

Ral 6009

Linealegno HF is also superb when painted one of the four standard colours (Ral 3009, 6005, 6007 and 6009) or on request in any colour available in the Ballan Ral colour chart.

### Wood treatment with special processing

New wood types, brushed to achieve a worn effect: brushing is carried out with a special technique.

They are also available made of mature natural wood, brought to new life through handcraft work processes.



The special Linealegno HF up-and-over garage doors are clad with mature natural Fir multi-ply through handcraft work processes.

The Defender-equipped safety cylinder and 6-point lock ensure a high level of protection against break-ins or tampering.

### The pass door is perfectly integrated and flush mounted.

The pass door is perfectly integrated in the door leaf. Completely wood clad to hide the metal parts also when open, the pass door can be placed centrally, and is a strength of the Linealegno HF garage doors in all respects. In fact, the safety cylinder and 6-point lock ensure optimal protection against prying open or tampering. The pass door threshold is just 100 mm high.



External view of Special HF up-and-over door, Douglas fir colour 1.



External view of Extra HF up-and-over door, okoumé colour 1.



External view of Extra Chic HF up-and-over door, okoumé painted in RAL 3003 colour.

## SPECIAL HF

Special HF model with herringbone slats (pitch 192 mm) pointing upwards. Outer panel thickness 15 mm, available in multi-ply okoumé wood, or multi-ply okoumé with oak or Douglas fir cladding. Or in multi-ply knot-free larch, also brushed. Total thickness of door leaf: 105 mm.

## EXTRA HF

Extra HF model with horizontal slats (pitch 200 mm) profiled at the top. Outer panel thickness 15 mm, available in multi-ply okoumé wood. Total thickness of door leaf: 105 mm.

## EXTRA CHIC HF

Extra Chic HF model with horizontal slats (pitch 200 mm), profiled at the top and separated by a vertical milled groove. Outer panel thickness 15 mm, available in multi-ply okoumé wood. Total thickness of door leaf: 105 mm.



## Linealegno HF up-and-over doors



Special Linealegno HF door, painted in RAL 6005 colour.

## DECOR HF a highly personal choice

It is called Décor HF and is the wooden garage doors that lets you choose the look. Thanks to a special production technique, Décor HF makes it possible to create graphical, geometric or curved patterns applied by pantograph on the 15 mm thick multi-ply okoumè wood cladding. A highly professional design is achieved, thanks to the small grooves with rounded edges to form an elegant finishing profile.



External view of Graphic HF, mod. 109, paint finish Ral 9001.

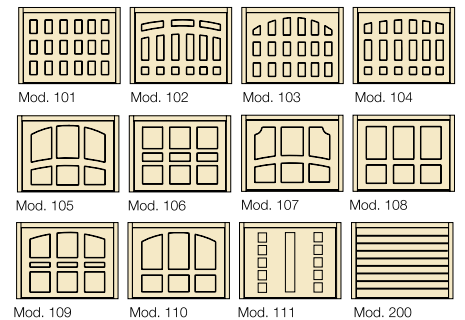

## Timber up-and-over doors RESERVE SIKURA HF :



External view of Reserve Sikura HF up-and-over door, covered with multi-ply okoumé and outer cladding in oak decorated by pantograph with horizontal slats with an 85 mm pitch. The outer cladding in oak, full treatment with colour 1 and the lock with Defender art. 94 are optional.

### SIKURA HF



from L 2000 to 6500  
from H 2000 to 3000

### AUTOMATION



## Timber up-and-over doors

### RESERVE SIKURA HF

Reserve HF Sikura HF structure is a counterweight up-and-over door with 120 mm side jambs.

The Reserve HF up-and-over door (without thermal insulation) is made of an internal steel structure clad externally with multi-ply okoumé and is available in different wood types, 15 mm thick, decorated by pantograph with vertical slats with an 85 or 170 mm pitch, or with horizontal slats with a 170 mm pitch. Manual or power-operated (ISY, ERG-2 City).



## Synergies to guarantee a superb aesthetic quality

If you need to conjugate the armoured door of your house with a garage door, ask Ballan to develop your project, with a perfect coordination among doors for design, colours and materials.

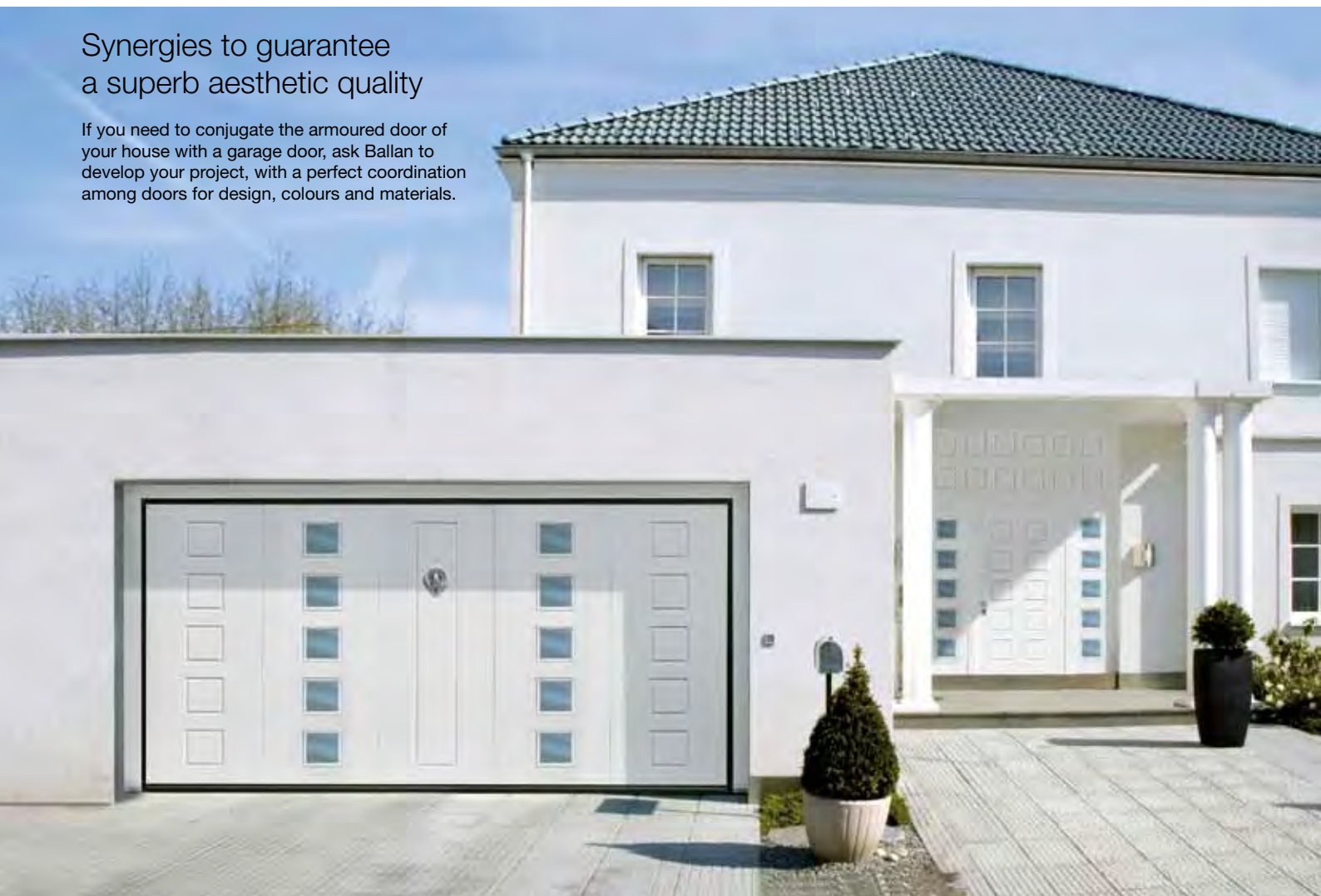

the simple solution without thermal insulation to combine elegance and sturdiness



External view of Reserve Sikura HF with pass door incorporated in the door leaf.  
The pass door with 90° opening is made with a tubular perimeter profile made of galvanized and painted sheet steel, reinforced horizontally; it is equipped with steel hinges, totally concealed; complete with aluminium handle and plate, the 3-point lock with double-bit key to ensure greater security.

External view of Reserve Sikura HF up-and-over door, multi-ply okoumé covering and oak outer cladding, decorated by pantograph with horizontal slats with a 170 mm pitch.  
The outer cladding in oak, full treatment with colour 2 and the lock with Defender art. 92 are optional.



Internal view of Reserve Sikura HF with Ballan ISY operator, pair of pre-fitted and pre-wired internal photocells (optional).  
The counterweight covers are made of metal sheet with a white paint finish similar to Ral 9016.



# Up-and-over doors: optional



Art. 78 - Aluminium handle with satin chrome finish and specially shaped grip.  
 Art. 79 - Aluminium handle with satin chrome finish and fan-shaped grip.



Art. 80 - Aluminium handle with satin chrome finish and shaped grip with two integrated LEDs.  
 Art. 81 - Aluminium handle with satin chrome finish and fan-shaped grip with two integrated LEDs.



## Aluminium handle

**Aluminium handle** with satin brass finish art. 94, or with satin chrome finish art. 98, also with European cylinder lock. On request also with drill-proof Defender safety cylinder (also mounted in the lock of the pass door, if provided).

Optional for Steel, MyFusion and Timber models.

**Art. 94** - Aluminium plate and handle with satin brass finish;  
**Art. 94D** - Aluminium plate and handle with satin brass finish for Defender security cylinder;  
**Art. 98** - Aluminium plate and handle with satin chrome finish;  
**Art. 98D** - Aluminium plate and handle with satin chrome finish for Defender security cylinder;  
**Art. 08** - Aluminium lower internal/external bridge handle (satin brass finish)  
**Art. 13** - Aluminium lower internal/external bridge handle (satin chrome finish).

## Secure grip handles



ABS handles are standard.  
As standard for Steel and Timber models.

## Shaped aluminium handle

**Ergonomic aluminium handle** designed and patented by Ballan, available in two finishes: satin chrome finish art. 96, or satin brass finish art. 92, also with European cylinder lock. On request with drill-proof Defender safety cylinder (also mounted in the lock of the pass door, if provided).

Optional for Steel, MyFusion and Timber models.

**Art. 92** - Aluminium ergonomic handle with satin brass finish;  
**Art. 92D** - Aluminium ergonomic handle with satin brass finish for Defender security cylinder;  
**Art. 96** - Aluminium ergonomic handle with satin chrome finish;  
**Art. 96D** - Aluminium ergonomic handle with satin chrome finish for Defender security cylinder.



Interior handle only for MyFusion models (standard) for manual lifting of the door leaf.

## Recessed aluminium handle

Patented and unassailable: Ballan' exclusive die-cast **aluminium recessed handle**.

The polyester based powder coating adds maximum resistance against harsh weather to the satin chrome outer coating (metal grey). Two shape variants of the central grip are available: fan shaped, stylishly designed, or shaped and multi-position, for optimal ergonomics. It also has an internal provision for two LEDs, which illuminate while the door is moving or when it is open. Its lock incorporates a drill-proof, tear-proof Defender with safety cylinder.

Art. 78 and art. 79 are standard for Linealegno HF models.  
Optional for MyFusion and Timber models.

**Art. 37** - Pairs of polished brass knobs;  
**Art. 32** - Pairs of bronze-finished brass knobs;  
**Art. 52** - Set of polished brass handles;  
**Art. 47** - Set of bronze-finished brass handles.

**Art. 57** - Set of polished brass handles;  
**Art. 42** - Set of bronze-finished brass handles;  
**Art. 82** - Set of aluminium handles with satin chrome finish;  
**Art. 12** - Polished brass internal handle;  
**Art. 7** - Bronze-finished brass internal handle;  
**Art. 87** - Satin chrome finished internal aluminium handle.

As standard for Linealegno HF models.  
Optional for Timber models.





## Steel up-and-over doors



The strength of Steel with the fantasy of colour



The Steel up-and-over doors are offered in standard Ral colours 6005, 6009, 7016, 7035, 8017, 8019, 9002, 9010, 9016.

Available on request in any colour from the Ballan Ral colour chart, for a choice of over 200 finishes!





## Steel up-and-over doors: heart of steel, freedom of choice

Products of the Steel range are made of pressed and galvanized steel sheet throughout. Thanks to the use of the best raw materials: the steel and our exclusive manufacturing techniques (such as cold welding, which eliminates the risk of corrosion), Ballan can vouch for the durability, strength and shape stability of up-and-over doors in the Steel range.

## More models and more customizations

Among its many advantages, the Steel line benefits from a providing a broad range: many models, for manual or electrical operation, also with slide-away door leaf. What ensures the maximum customization of the door is the range of optional fittings and colours from Ballan's chart.



### The three structures for Steel (unit of measurement 10 mm)



#### SPAZIO SPAZIO HF



from L 2000 to 3300  
from H 2000 to 2650

#### AUTOMATION

*Sim*  
ballan

*ERG2*  
ballan

#### SIKURA HF

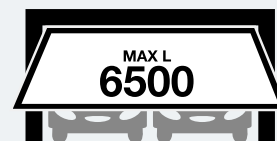

from L 2000 to 6500  
from H 2000 to 3000

#### AUTOMATION

*Sim*  
ballan

*ERG2*  
ballan

N.B.: Steel models may have different maximum dimensions depending on the required options.

### New colour chart with mica-based colours

These special paints are made of acrylic resins mixed with mica-based pigments to give the refined effect of antique wrought iron. Their particular composition makes them ideal for doors exposed to particularly harsh weather.

Ballan mica-based colour chart:  
Titanium grey 5, Ballan grey,  
Graphite grey 3, Anthracite black 2,  
Light blue 7, Velvet green 6,  
Similar to Corten Bal 1, Dark brown 4.





## Steel up-and-over doors



External view of Zink GT Spazio HF up-and-over door made of galvanized steel sheet, SIM operator is optional.



**GT**  
hardened joints



External view of Zink GT Sikura HF up-and-over door made of galvanized steel sheet. The RAL 7003 colour and ISY operator are optional.



External view of Zink Sikura HF City up-and-over door made of galvanized steel sheet, and non-protruding door leaf. The RAL 5014 colour and ERG-2 CITY operator are optional.



### ZINK GT SPAZIO HF

Zink GT Spazio HF structure up-and-over door made of galvanized steel sheet. The steel plates are joined using hardened joints (GT): a cold welding that increases corrosion resistance.



### ZINK GT SPAZIO

Zink GT Spazio structure up-and-over door made of galvanized steel sheet. Available only for manual operation, without 25 mm clearance and perimeter seals.

### ZINK SIKURA HF

Zink Sikura HF up-and-over door with 120 mm side jambs, made of high thickness galvanized steel.

### ZINK SIKURA HF CITY the advantage of not protruding

Zink up-and-over door Sikura HF City with 120 mm side jambs, made of high thickness galvanized steel and non-protruding door leaf. It is the ideal solution for garages located next to a pedestrian walkway or with arched openings.

The up-and-over doors can also be used to create solutions of high aesthetic impact such as Corten steel sheet cladding. The main characteristic of Corten steel is its excellent resistance to corrosion by atmospheric agents, as natural oxidation stabilises after some time, forming a protective layer that will remain unaltered over time. The resulting oxidised colour gives surfaces a warm and intense appearance and leads to many aesthetic solutions inspired by an unusual "sophisticated rusty look" - evocative of antique, weathered steel.



### Pass door (optional)

The pass door, fitted with aluminium hinges and complete with handle and lock, can be side or centrally mounted, according to the size of the up-and-over door.



External view of Zink Sikura HF structure and pass door with 3 locking points.



On demand, the anti-intruder protection of pass doors can be improved with a 3-point lock (including with Defender) complete with 3 security bolts on the hinge side.

### Incorporated fixed panel window (optional)



External view of Zink Sikura HF up-and-over door, with fixed panel window incorporated in the leaf with 2 frames for glass (not included). Also available for the Line model.



External view of the Line Sikura HF up-and-over door, with RAL 1014 finish (optional).

## LINE SIKURA HF

External view of Line up-and-over door Sikura HF structure. The Line style variant is a door with horizontal slats with a vertical central slat and is made of high thickness galvanised sheet steel.

### Ventilation holes for Zink GT (optional)

Zink GT up-and-over door, Spazio structure in galvanised steel sheet and ventilation holes on the lower section of the mobile leaf (holes 60x20 mm).





## Up-and-over doors: the three structures



### Spazio HF structure

Available for manual or electrical operation, the Spazio HF structure features 80 mm side jambs to maximise the available transit width.

The 110 mm upper beam is made of 8/10 mm thick sheet metal. Designed for garages with small entrance dimensions, no greater than 3300 mm wide and 2650 mm high.

Made of pressed, galvanized steel sheet, the door leaf is made of a 60 mm section electrically welded tubular perimeter profile. Complete with lateral strikers and counter-striker and removable counterweight sleeves (to allow inspection of cables and counterweights), made of galvanized steel and/or steel sheet pre-painted with similar to RAL 9016 finish

Since it is HF operator ready, it can be retrofitted with an operator in full compliance with the EN 13241-1 Product Standard. This is because the HF retrofit provision includes 25 mm safety clearances between lever mechanisms, perimeter seals between door leaf and fixed frame (side jambs and fixed panel), reinforced lever arms and self-centring brackets to ensure correct closing of the door leaf.

Spazio HF is equipped with a Cable break device to prevent the door leaf from dropping accidentally, CE marking plate and DoP Declaration of Performance.

Operator: SIM-1, SIM-2.



### Sikurtec HF structure (only for MyFusion)

Available for manual or power operation, Sikurtec HF is the structure with 120 mm side jambs made of 15/10 mm thick steel sheet (like Sikura) and 110 mm fixed panel made of 8/10 mm thick steel sheet (like Spazio). Can be produced up to L 3500 mm and H 2650 mm.

Made of pressed, galvanized steel sheet, the door leaf is made of a 60 mm section electrically welded tubular perimeter profile. Complete with lateral strikers and counter-striker, and removable counterweight sleeves (to allow inspection of cables and counterweights), made of galvanized, pre-painted steel sheet with finish similar to RAL 9016.

Since it is HF operator ready, it can be retrofitted with an operator in full compliance with the EN 13241-1 Product Standard. This is because the HF retrofit provision includes 25 mm safety clearances between lever mechanisms, perimeter seals between door leaf and fixed frame (side jambs and fixed panel), reinforced lever arms and self-centring brackets to ensure correct closing of the door leaf.

Spazio HF is equipped with a Cable break device to prevent the door leaf from dropping accidentally, CE marking plate and DoP Declaration of Performance.

Available with slide-away leaf: Sikurtec HF City.

Operator: SIM-1, SIM-2, ERG-2 CITY.

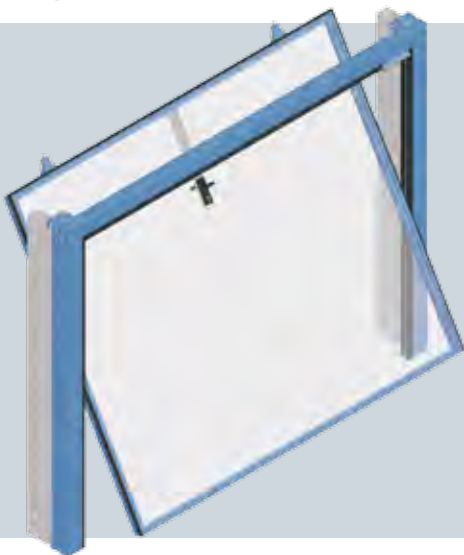

### Sikura HF structure

Available for manual or powered operation, Sikura HF is the structure in heavy-gauge steel sheet with maximum dimensions of up to 6500 mm wide and 3000 mm high. With 120 mm side jambs made of 15/10 mm steel sheet and 100 mm upper fixed panel, also made of 15/10 mm sheet steel.

Made of pressed, galvanized steel sheet, the door leaf is made of an 80 mm section electrically welded tubular perimeter profile. Complete with lateral strikers and counter-striker, and removable counterweight sleeves (to allow inspection of cables and counterweights), made of galvanized, pre-painted steel sheet with finish similar to RAL 9016.

Thanks to its HF ready for drive provision, Sikura HF can be retrofitted with an operator in compliance with the EN 13241-1 Product Standard. This is because the HF retrofit provision includes 25 mm safety clearances between lever mechanisms, perimeter seals between door leaf and fixed framework (side jambs and fixed panel), and reinforced and self-centring lever arms to ensure correct closing of the door leaf.

Spazio HF is equipped with a Cable break device to prevent the door leaf from dropping accidentally, CE marking plate and DoP Declaration of Performance.

Available with slide-away leaf: Sikura HF City.

Operator: ISY, ERG-2 CITY.



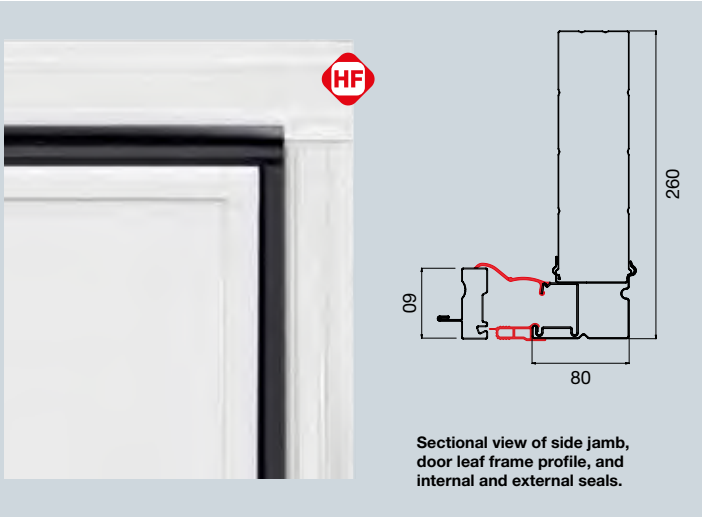

Spazio HF structure more compact, for more transit width



Designed for garages with entrances that are small up to L 3000 mm and H 2650 mm.

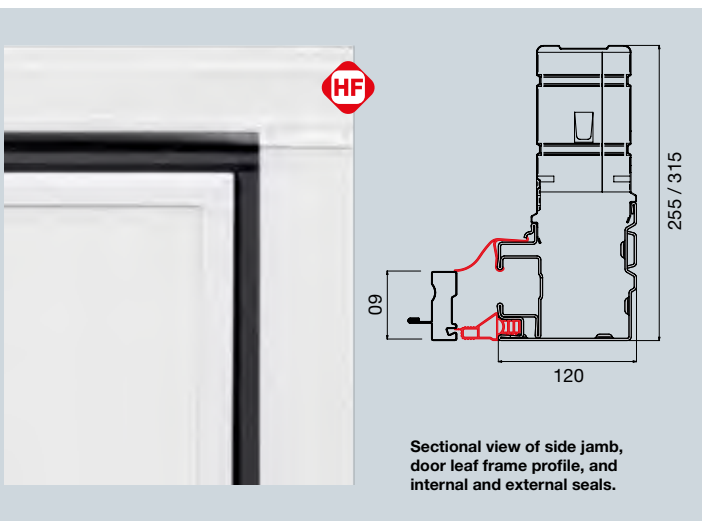

Sikurtec HF structure universal and therefore the most versatile



Only for MyFusion. Maximum dimensions up to L 3500 mm and H 2650 mm.

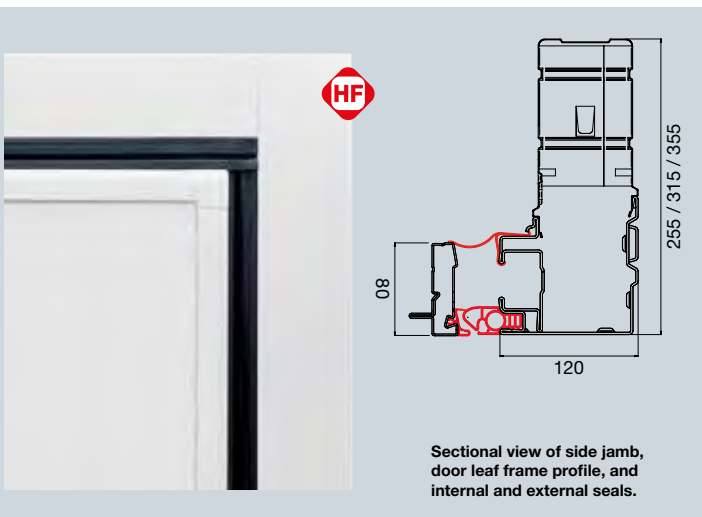

Sikura HF structure for the largest dimensions and maximum safety

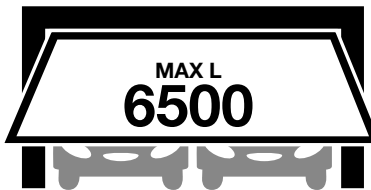

Maximum dimensions up to L 6500 mm and H 3000 mm.

The three structures that meet all needs

Ballan has created a range of structures suitable to match the characteristics of any type of garage, as to the size of the entrance and how it will be used (consider the significant difference between a door for a one-car garage and a door for the communal garage of an apartment building).

Does the tailor-made door really exist?

Certainly, by combining Ballan's structures and models.



Watch the video of the MyFusion up-and-over doors with the three structures



## Up-and-over doors: the operators

### Welcome to the future with operators entirely designed by Ballan

Perfectly integrated with the door structure, rigorously compliant with CE marking and guaranteed for thousands of operating cycles,

**SIM** and **ISY operators by Ballan** can be programmed with a simple click and they interact with users informing them, for example, when maintenance is required.

If your garage is next to a pedestrian walkway or if it is installed in an arched opening, Ballan recommends the safety and reliability of the City slide-away garage door with its **ERG-2 CITY** operator.

### It just takes a click to connect to the up-and-over door

The Smart remote control with its original black-and-white colour only needs a click to operate the garage door remotely, without the least effort. A convenience that it is difficult to give up.



### The guarantee of the CE marking

The up-and-over doors equipped with operators are provided with CE Marking and EC Declaration of Conformity for automatic use.

All electrical and electronic components bear the CE marking in conformity with the European electromagnetic compatibility directive.

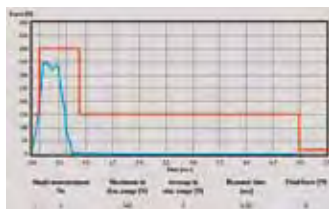

#### Force control and limitation

The force limitation device stops - and reverses - the movement of the door in front of any obstacle (max. permissible effort 400 N).

The red line in the chart alongside shows the parameters specified by the Product Standard. On the same graph, the blue line shows that the force measured on Ballan power-operated doors is well below that established by law.



### Thanks to the kit, the door is ready for use

Kits are supplied with the chosen operator installed in the door and do not require on-site testing because the electrical system is installed and pre-wired. For all intents and purposes it can be likened to a home appliance because there's no need to call an electrician to start using it. Simply connect the door to the garage's electrical system and it is ready to use, saving time and money.

- With the **GOLD KIT** the door is supplied complete with the chosen operator and fully equipped with options.
- **SILVER KIT**: the door is supplied complete with the chosen operator, as for the GOLD KIT, but in this case without the LED flashing light with integral antenna.
- **BASIC KIT**: designed to meet the needs of clients seeking an inexpensive operator, again pre-installed on the door.



## The SIM, ISY, and ERG-2 CITY operator kits include:

### **GOLD KIT**

- 1 or 2 24 V motors with VISg (Verified Instant Safety-g): the low power consumption on-board control unit with command buttons that includes the newly patented gravity accelerometer. The kit includes the LED courtesy lights, the single lever arms and the motor mounts;
- 1 integrated two-channel receiver board (rolling code technology);
- 1 Smart remote control, FM rolling code with 3 and 5 channels;
- 1 pair of pre-wired internal photocells pre-fitted to the up-and-over door;
- 1 LED flashing light with integral antenna, assembled and pre-wired (mounted on the upper fixed panel of the up-and-over door always on the left when viewed from outside the garage);
- door leaf lower rubber seal (supplied disassembled);
- internal unlocking device;
- CE Declaration of Conformity.

### **SILVER KIT**

- 1 or 2 24 V motors with VISg (Visual Instant Security-g) control system: the low power consumption on-board control unit with command buttons, utilising the newly patented gravity accelerometer. It kit includes LED courtesy lights, single lever arms and the motor mounts;
- 1 integrated two-channel receiver board (rolling code technology);
- 1 integral antenna;
- 1 smart remote control, FM rolling code with 3 and 5 channels;
- 1 pair of pre-wired internal photocells pre-fitted to the up-and-over door;
- door leaf lower rubber seal (supplied disassembled);
- internal unlocking device;
- CE Declaration of Conformity.

### **BASIC KIT**

- 1 or 2 24 V motors with VISg (Visual Instant Security-g) control system: the low power consumption on-board control unit with command buttons, utilising the newly patented gravity accelerometer. It kit includes LED courtesy lights, single lever arms and the motor mounts;
- 1 integrated two-channel rolling code receiver board;
- 1 integral antenna;
- 1 smart remote control, FM rolling code 3/5 channels;
- rubber door leaf lower guard (supplied disassembled);
- internal unlocking device;
- CE Declaration of Conformity.



## Up-and-over doors: the operators

**SIM**  
ballan

SIM Ballan:  
the safe and reliable  
operator

Operator for all MyFusion

models with:

- Spazio HF structure
- Sikurtec HF structure.

This operator is supplied in three  
alternative kits:

- GOLD KIT
- SILVER KIT
- BASIC KIT



Internal view of MyFusion Sikurtec HF up-and-over door, with SIM-2 operator and pair of pre-fitted and pre-wired internal photocells (optional).



**The Ballan SIM-1, SIM-2L e SIM-2 operators** (developed and patented by Ballan) incorporate the motor, the VISg control system with patented gravity accelerometer, and the control panel in a single unit in a black plastic housing and mounted on the door leaf, with electrical wiring routed through a black conduit.

The strengths of the SIM Ballan operator:

- the single support and drive arm on the mobile section is suitably shaped to observe safety clearances and avoid finger pinching and shearing hazards;
- variable force during opening and closing movements.
- by adjusting the force used on each cycle the operator is more sensitive and at the same time more reliable, since it automatically compensates variations caused by friction, temperature and electrical power supply;
- the presence of a user interface to enable programming of door operation and constant information on the operator status, malfunctions and when maintenance is required.

The Ballan patented single support and drive arm on the mobile section is suitably shaped. The operator utilises two irreversible low voltage gearmotors. The courtesy light is incorporated in the protective housing



The SIM-1 operator in the MyFusion door has a central motor applied on a central rail (mounted on the door leaf) with motor base and guide tubes.





## Ballan ISY: the most compact and efficient operator

**Operator for all MyFusion  
models with:  
- Sikura HF structure.**

For this operator three alternative  
kits are available:

- **GOLD KIT**
- **SILVER KIT**
- **BASIC KIT**



**Internal view of MyFusion Sikura HF with ISY operator and pair of pre-fitted and pre-wired internal photocells (standard).**



**Ballan's ISY operator** (developed and patented by Ballan) incorporates the motor, the VISg control system with patented gravity accelerometer and the control panel in a single unit mounted on the door leaf, thereby ensuring a very compact and aesthetically appealing system.

Strengths of the Ballan ISY operator and features that make this drive outstanding:

- the single support and drive arm on the mobile section is suitably shaped to observe safety clearances and avoid finger pinching and shearing hazards;
- variable force during opening and closing movements;
- recalculation of the force employed at each cycle; this makes the operator more sensitive (safer) and simultaneously more reliable (more functional) because it provides automatic compensation for variations due to friction, temperature and electrical power;
- the presence of a user interface to enable programming of door operation and constant information on the operator status, malfunctions and when maintenance is required.

**The Ballan patented single support and drive arm on the mobile section is suitably shaped. The operator is integral with the door and utilises two irreversible low voltage gearmotors. The courtesy light is incorporated in the protective housing**



## VISg system: maximum sensitivity in control

On Ballan operators SIM, ERG and ISY the 24V gearmotor is managed by the patented Control System VISg (Verified Instant Safety gravity).

Thanks to the exclusive use of accelerometer technology (Electronic Gravity Accelerometer), VISg uses 4 different and independent modes to detect obstacles, both during opening and closing, to detect not only impact but also collision (for example inadvertent contact with a car bumper), which can occur in directions different to those of door movement, but are detected nonetheless. In the case of impact or collision during closing, the control system interrupts movement immediately and inverts the door travel. If impact or collision occurs during opening, the control system immediately interrupts movement to enable removal of the obstacle.





## Up-and-over doors: the operators



ERG-2 CITY Ballan:  
the practical and reliable  
operator for slide-away City  
structure

**Operator for all models  
MyFusion with:**  
- Sikurtec City HF structure  
- Sikura City HF structure.

This operator is supplied in three  
alternative kits:

- **GOLD KIT**
- **SILVER KIT**
- **BASIC KIT**



Internal view of MyFusion Sikura HF City up-and-over door, with ERG-2 CITY operator and a pair of pre-fitted and pre-wired internal photocells (standard).



**The Ballan designed ERG-2 CITY** operator is completely safe because the telescopic drive arm and HF retrofit provision complies with the prescribed accident-prevention safety clearances (European Directive). It incorporates the motor, VISg control system with gravity accelerometer, and control panel in a single unit housed in a black plastic housing and mounted on the door leaf, with electrical wiring routed through a conduit.

The ERG-2 CITY drive, which is designed for slide-away door models (City), features two lateral motors mounted on two rails (fitted at each side of the door leaf) with motor base and telescopic arms.

Strengths of the ERG-2 CITY operator:

- the design of the telescopic motor arm is compliant with safety clearances and avoid finger pinching and shearing hazards;
- variable force during opening and closing movements.
- by adjusting the force used on each cycle the operator is more sensitive and at the same time more reliable, since it automatically compensates variations caused by friction, temperature and electrical power supply;
- the presence of a user interface to enable programming of door operation and constant information on the operator status, malfunctions and when maintenance is required.

**The Ballan patented single support and drive arm on the mobile section is suitably shaped. The operator utilises two irreversible low voltage gearmotors. The courtesy light is incorporated in the protective housing.**



If your garage is next to a pedestrian walkway or if it is installed in an arched opening, Ballan offers the garage doors with City slide-away leaf and ERG-2 CITY operator

# Operator accessories

## Operator accessories SIM / ISY / ERG-2 CITY

(Accessories may already be included in the various kits, or be available as options.).

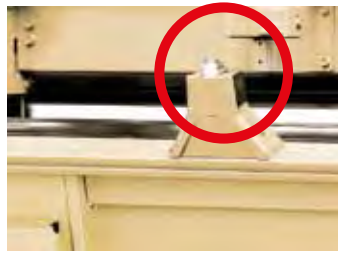

More security with the new E-Lock for ISY operators



N.C. contact for home automation  
- N.C. contact optional only with power-operated up-and-over door.  
- N.C. contact optional for pass door (with manual or power-operated up-and-over door).

On all Ballan up-and-over doors, the motors are mounted on the door leaf, and their irreversible design guarantees a good level of burglary resistance.  
**The E-Lock system (exclusive electric lock) is an accessory that seamlessly combines with the Sikura HF structure and the ISY operator to increase security even further.** It can be installed (optionally) completely integrated in the upper steel beam of power-operated up-and-over doors with ISY operators and when automatic closure is activated, the device acts on both internal latches, keeping the door locked in place until another opening command is given, thereby increasing burglary resistance.

**The optional N.C. contact (Normally Closed) is an accessory that reports the state of the door: N.C., normally closed when the door is closed.** It is independent of the operator and can be connected to the alarm and/or home automation system, through the cable with terminal block located at the top right viewed from inside the up-and-over door. Provided already installed in the door.



Smart remote control, FM rolling code with 3 and 5 channels.



Back-lit code keypad complete with 2-channel board and shielding. Wired power supply. (optional)



Badge reader complete with 2-channel board with shielding, provided with master card and wired power supply. (optional)



The external unlocking device for use in the event of electrical power failures. (optional)



Position on the right internal view of the external board for wiring of accessories.



Accessories board connected to the VISg via bus cable. (optional)



Terminal block for cabling of flashing light and antenna always located in the upper right hand as viewed from inside. (optional)



Low power consumption external receiver with 2/4 outputs for 1000 users with back-up card included. For use with existing operators on site an additional antenna is advisable. (optional)



External flashing led unit, with integrated antenna, mounted and pre-wired. (optional)



Movement indicator flashing light 24 V, with antenna for remote controls. (optional)



Position of LED flashing light, for flush mounting, mounted outside on the upper steel beam. (optional)



Position of LED flashing light, with support for surface mount, mounted outside on the upper steel beam. (optional)

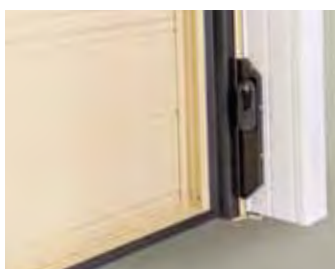

Pair of pre-wired internal photocells, pre-installed on the up-and-over-door. (optional)



Additional loose photocells, for surface mounting (not recessed). (optional)



Buffer batteries 12 V for up-and-over door operation in the event of a power failure. (optional)



Pair of high power LED lights, installed in the lower section of the door leaf, pre-wired and suitable for lighting the transit zone during operation. (optional)  
Not available for SIM-2L operator.



# Up-and-over doors: technical specifications

## FLUSH MOUNTED SPAZIO HF STRUCTURE

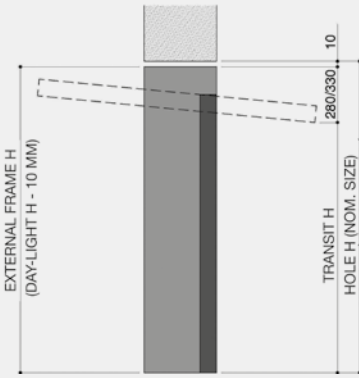
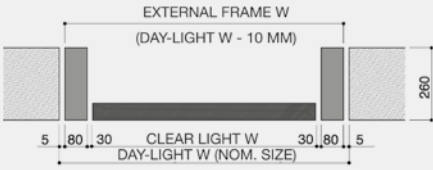

## SURFACE MOUNTED SPAZIO HF STRUCTURE

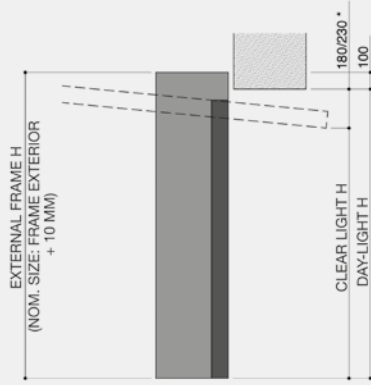
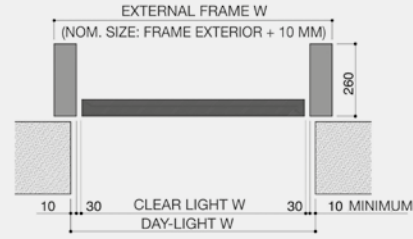

## FLUSH MOUNTED SIKURTEC HF STRUCTURE (only MyFusion)

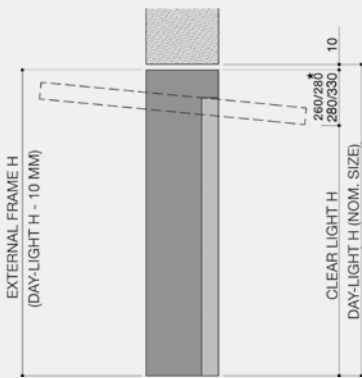
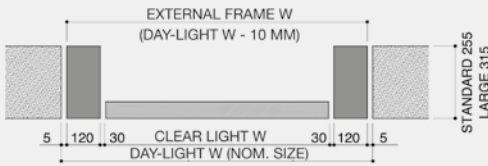

(\*) For the Sikurtec HF structure with FLUSH MOUNTING and overall maximum size L 3500 x H 2400 mm the size is 260/280 mm, from H 2400 to H 2650 mm it is 280/330 mm.

## SURFACE MOUNTED SIKURTEC HF STRUCTURE (only MyFusion)

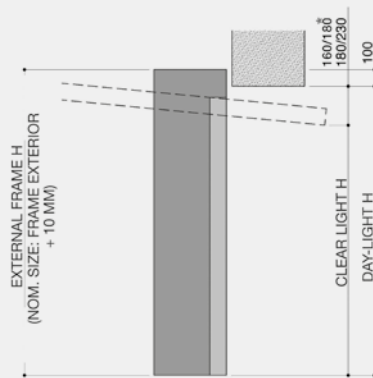
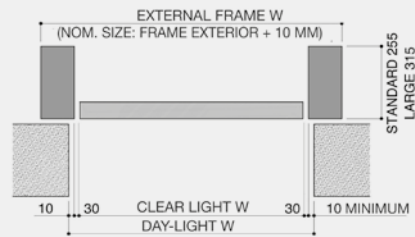

(\*) For the Sikurtec HF structure with SURFACE MOUNTED and overall maximum size L 3500 x H 2400 mm the size is 160/180 mm, from H 2400 to H 2650 mm it is 180/230 mm.

## Section of profile of door leaf with rounded edge for MyFusion up-and-over doors.

Section of profile of door leaf with rounded edge, standard on MyFusion up-and-over doors.

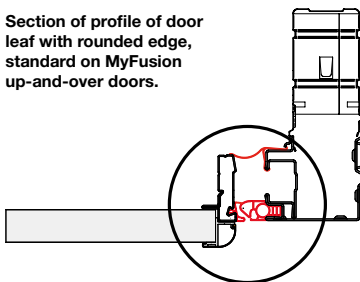

Section of door leaf profile with rounded edge and covers (optional) mounted in front of the structure, for MyFusion up-and-over doors.

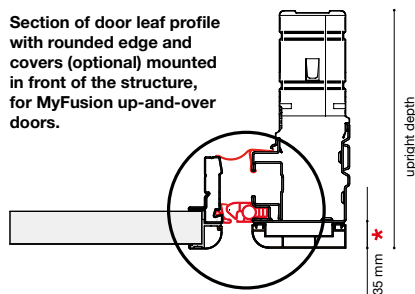

\* In the MyFusion up-and-over door with covers assembled, always add 35 mm to the "upright depth" of all structures.



**FLUSH MOUNTED  
SIKURA HF STRUCTURE**

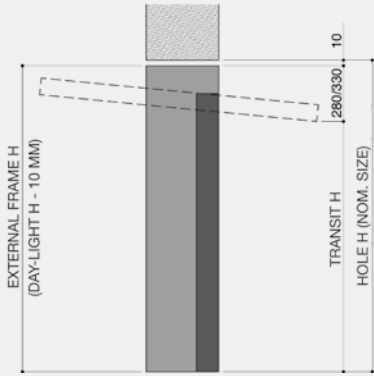
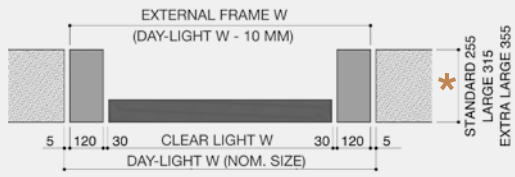

**SURFACE MOUNTED  
SIKURA HF STRUCTURE**

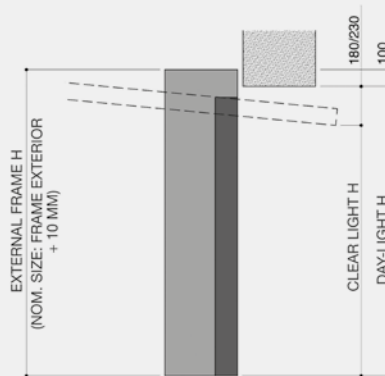
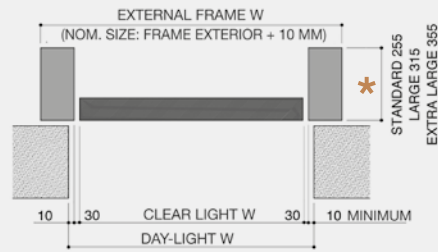

**FLUSH MOUNTED  
SIKURA CITY HF STRUCTURE**

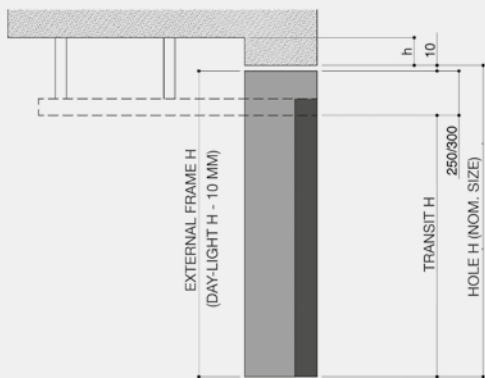
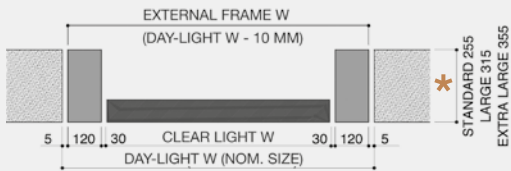

**SURFACE MOUNTED  
SIKURA CITY HF STRUCTURE**

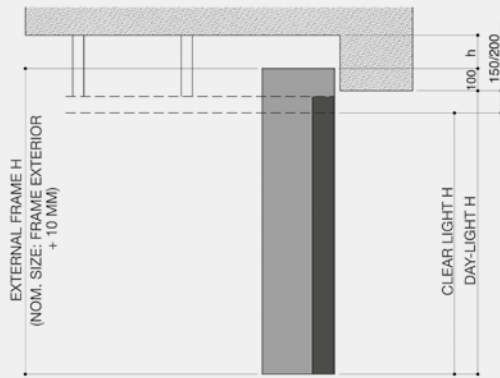
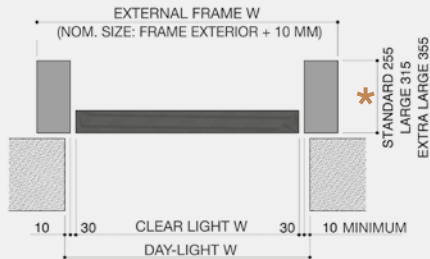

\* Overall size for Linealegno HF  
STANDARD 270 mm  
LARGE 330 mm  
EXTRA LARGE 370 mm

**N.B.:**

In the up-and-over door with retrofit provision for HF operators rubber seals are fitted in the side jambs of the structure and although they reduce the passage width by 60 mm, they cushion the impact in case of contact.



## Sectional doors

**Ballan sectional doors don't take up any room, inside and outside the garage. They free up space and multiply the options. They provide countless combinations, thanks to the variety of models and finishes.**







## New Age XT sectional doors



### New Age sectional doors: superior style that is not afraid of imitations

There are manufacturing operations that change times. The New Age sectional doors changed the world of garage closures forever.

Its unique features are recognized at first glance: its clean and harmonious look is obtained thanks to the revolutionary jointed aluminium insulated panels that are 100% made in Ballan, and that eliminate the use of traditional internal hinges.

New Age embodies extreme attention to detail, from its rich range of options, such as side track covers and multifunction handles, the painting of al components in the same colour as the panels.

The accuracy and the originality of Ballan's production process make each New Age sectional door unique, reliable and tailor made for its particular architectural context.

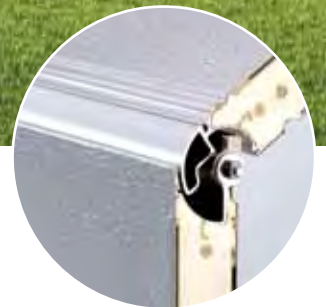

## Can beauty be practical?

Yes, when you choose a door from with exclusive technology.

In fact Ballan holds an international patent on the aluminium joint and it is, produced entirely by the company using a specially-made manufacturing system.

All its mechanical parts are incorporated in the door's structure, in order to obtain an elegant, linear design that also makes it impossible to pinch fingers in the joints between the panels.

The sturdiness, insulation and soundproofing of its panelling, in addition to the quietness of the joint, round out the performance of the New Age line.





## New Age XT sectional doors

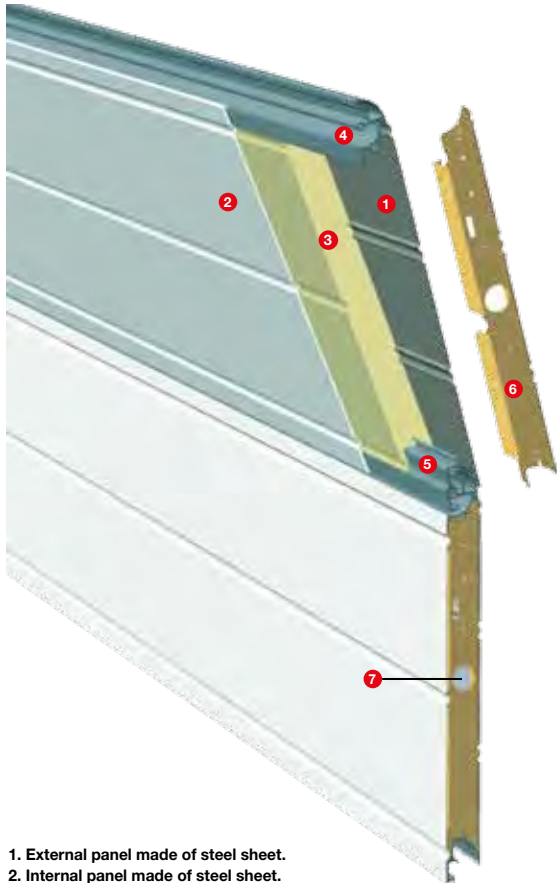

1. External panel made of steel sheet.
2. Internal panel made of steel sheet.
3. High-density polyurethane foam (49 kg/m<sup>3</sup>).
4. Upper aluminium profile.
5. Lower aluminium profile.
6. Side cover made of high thickness steel.
7. Hole to inject polyurethane foam, larger to enable optimal foam dispersion, and closed by a high strength cap.

## Panels, totally designed and produced by Ballan

The panelling of the New Age XT line is entirely made in Ballan: each element is made individually in the press, the embossed stucco and embossed wood finishes of the pre-painted galvanized steel panels are designed and manufactured by Ballan. An original manufacturing system, designed by the company, ensures high accuracy.

The insulated panels with aluminium joints (patented by Ballan) of the New Age XT line are 40 mm thick and 400 mm high and are made of pre-painted galvanized sheet steel, made up of a lower and an upper aluminium profile, joined by two steel sheet facings and closed laterally by two high thickness steel covers. The two aluminium profiles form the joint the movement of which is made possible by bushings made of self-lubricating material, which also ensure perfectly silent operation.

A totally HCFC free internal flame-retardant polyurethane foam core completes the panel, providing insulation and soundproofing as evidence of the company's respect for the environment.

**The New Age XT sectional door is certified with class 3 wind load resistance.**

## Class 3 wind load resistance



The company manufactures its garage doors following the reference standards as required by the Construction Products Regulation CPR 305/2011.

The manufacturer must submit the garage door for initial testing to a Notified Body as per product standard EN 13241-1:

- wind load resistance (**Class 3 for New Age XT**);
- opening safety;
- operating force for power-operated doors.

## Technical characteristics of the panel

Values measured at room temperature

Thickness	Height	Thermal conductivity $\lambda$		Thermal conductance K		Average density	Weight	
		$\frac{W}{m \cdot K}$	$\frac{Kcal}{m \cdot h \cdot ^\circ C}$	$\frac{W}{m^2 \cdot K}$	$\frac{Kcal}{m^2 \cdot h \cdot ^\circ C}$		$\frac{Kg}{m^3}$	$\frac{Kg}{m^2}$
40	400	0,023	0,019	0,60	0,52	49	5,5	13,8



Ballan manufactures the New Age XT garage doors panels itself.

An original manufacturing system, designed by the company, ensures high geometric accuracy, a superior mechanical quality and perfectly flat panels.

## The advantage of energy saving

Modern residential building requires the search for excellence in terms of energy saving and environmental sustainability. That is why, in addition to being insulated, **New Age XT door panels can be requested with thermal break: the interruption of the heat flow passing through the aluminium joint, and therefore obtain a coefficient with a low thermal transmittance value.**

This is a result that saves money and complies with the requirements for energy efficiency improvement of buildings and, ultimately, benefits the environment.

A topic Ballan has always been very concerned about.

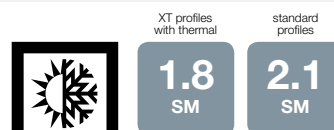

## New Age XT thermal efficiency

The New Age sectional door with standard arrangement and sizes (e.g. L 3500 x H 2500 mm), has a thermal transmittance of approximately\*:

PROFILES WITH THERMAL BREAK (New Age XT with vertical seals) • 1.8 W/m<sup>2</sup>K surface mounted.  
STANDARD PROFILES • 2.1 W/m<sup>2</sup>K surface mounted.

(\*) The stated thermal transmittance values are to be considered guideline only, and apply to standard surface mounted up-and-over doors ranging from 8 to 10 m<sup>2</sup>. Only on request at the time of ordering, Ballan SpA will issue a thermal transmittance declaration specific to the garage door requested.

...any sectional door

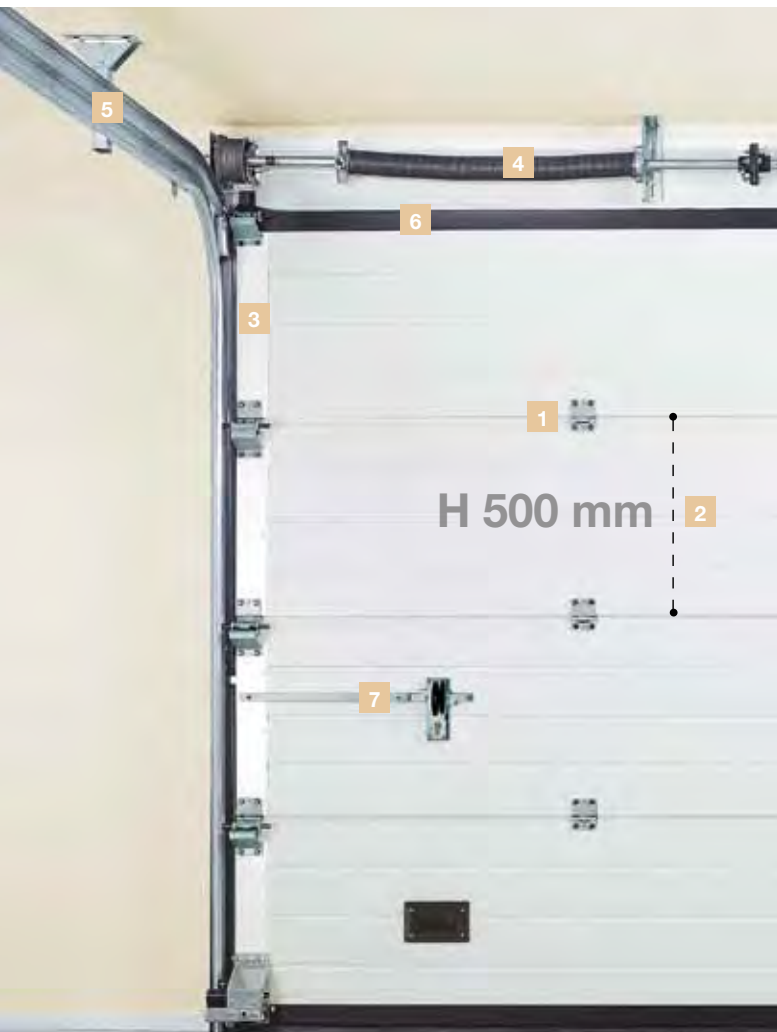

Internal view of a typical sectional door present on the market.

...the New Age XT sectional door

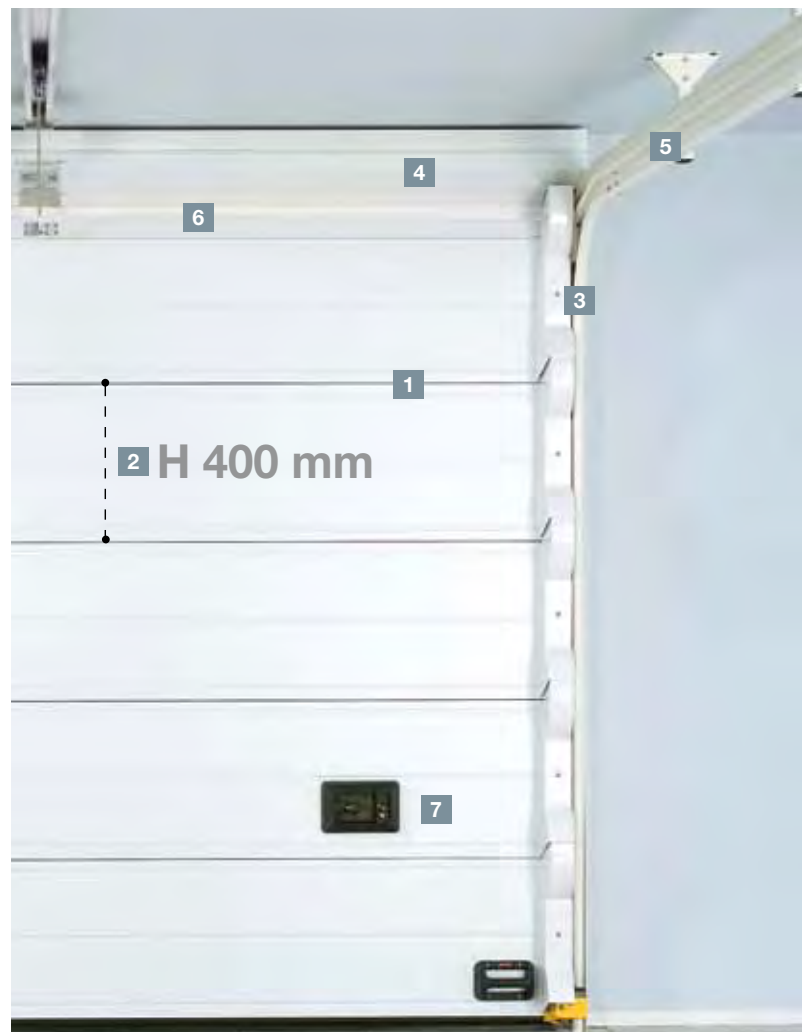

Internal view of a power-operated New Age XT sectional door.



## It's easy to see the differences

This happens only for products with a strong personality: their style can be recognized at a glance. A unique style, the fruit of countless differences, that you can understand comparing New Age XT with any other sectional door.

- 1 The panels are joined by means of a patented anti-pinch aluminium joint, not using unsightly hinges.
- 2 The panels are smaller than the industry standards panels (400 mm against the usual 500/600 mm).  
A size that, together with its aluminium profiles, makes the panel stronger, bend-proof, and that ensures that it works perfectly, mechanically.
- 3 The side tracks are protected by covers that move with the door (optional).
- 4 The shaft with springs, which controls the door's operation, is protected by a specially shaped cover that helps prevent accidents and improves its looks.
- 5 The tracks and rails are epoxy powder coated in white similar to Ral 9016 for cosmetic purposes.
- 6 The upper steel profile is painted the same colour as the panelling and hides the rubber seal.
- 7 The multifunction handle elegantly brings together the functions of closing and manual lift (optional).

## New Age XT is also different outside

The uniformity of its panelling is not only an aesthetic value: it is also functional, since it makes it impossible to pinch fingers in the joint between the panels.





## New Age XT sectional doors

### The differences that make New Age XT top-notch

Outside, the upper fixed panel is self-supporting, can replace the free headroom if necessary and makes it possible to mount the door both flush and surface mounted with maximum simplicity, moreover it is also flush with the side jambs for an excellent aesthetic result.

Also on the outside, the side jambs are faced with by embossed and painted sheet metal profiles. The outer upper and lateral rubber seals are invisible because they are respectively inserted inside the fixed panel and in the jambs.

Inside, the shaft with springs is protected by a special shaped shaft cover that becomes a single unit with the fixed framework.

### Differences viewed from outside



The upper self-supporting fixed panel of the New Age XT structure is clearly visible, flush with the door and the rubber seals are invisible because they are fitted inside the leaf and in the jambs (flush mount).

1

The **vertical tracks** are covered with embossed and painted sheet metal profiles painted the same colour as the panels. Moreover, the profiles are flush with the upper fixed panel.

2

The 15 mm **thick upper fixed panel** is self-supporting, painted the same colour of the door and provided as standard. Thanks to it the door can be easily installed in any position (flush or surface mounted).

3

The **upper seal** is fitted in the fixed panel and is therefore invisible from outside.

4

The **lateral seals** are also concealed, because they are fitted in the lateral tracks.

5

The **special lower seal** is "skirting" i.e. it makes it possible to mount the door both flush and surface mounted, always hiding the "gap" between the entrance and the inside of the garage.

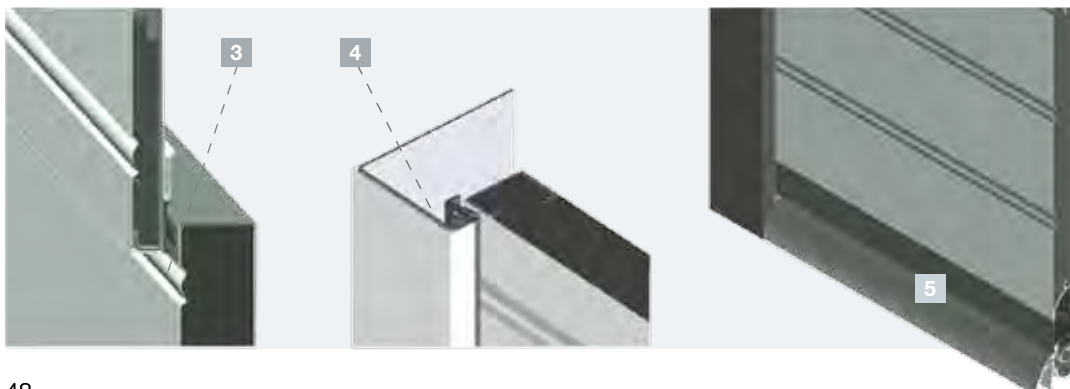



optional



The special optional Ballan-patented track covers enclose the tracks and rollers, ensuring maximum protection against accidents. Also, they do not take up space because they are fitted directly to the panels and therefore follow their movement. Optional for New Age XT.

The special shaped shaft cover for New Age XT structure, made of embossed galvanized sheet steel pre-painted a colour similar to Ral 9016, which protects from moving parts during the operation of the door. It is designed to form a single unit with the fixed framework.



The differences viewed from inside



Internal view of a New Age XT sectional door, the modular track covers and the chain-driven operator are optional.



It is designed to form a single unit with the fixed framework, the special shaped shaft cover provided as standard for the New Age XT structure is made of embossed galvanised steel sheet pre-painted with similar to Ral 9016.

optional  
special modular  
protection covers



# New Age XT sectional doors



External view of Lake XT sectional door, embossed stucco finish. The external RAL 1000 colour and handle art. 70 are optional. The panel interior has an embossed stucco finish in white similar to Ral 9016.



External view of Air XT sectional door, embossed stucco finish. The external RAL 3022 colour and handle art. 68 are optional. The panel interior has an embossed stucco finish in white similar to Ral 9016.



External view of River XT sectional door, embossed stucco finish. The external RAL 6021 colour and handle art. 68 are optional. The panel interior has an embossed stucco finish in white similar to Ral 9016.

## LAKE XT

The strength of the New Age line is the perfect joining of its panels, made possible by our exclusive patented joint system, that makes the panelling extremely smooth and compact. In the light of its extremely linear look, the Lake model offers flat panels that highlight the colour choice. Available in several external surface finish versions, embossed stucco, embossed wood, smooth and sandgrain. Internal side with white embossed stucco finish in white similar to Ral 9016.



## AIR XT

While the leading feature of the New Age door is the perfect joining of its panels made possible by our exclusive patented joint system, the second feature is its vast customisation, since the panels can be painted with any colour from Ballan's RAL range. The Air model is characterized by the addition of a horizontal rib in the panel. Available in several external surface finish versions, embossed stucco, embossed wood, smooth and sandgrain. Internal side with white embossed stucco finish in white similar to Ral 9016.



## RIVER XT

The New Age sectional door offers a range of aesthetic and chromatic solutions which make it suitable for any environment. In the River model, horizontal ribbing aesthetically balance the panelling, giving it a light and modern look. Available with external embossed stucco finish. Internal side with white embossed stucco finish in white similar to Ral 9016.





## Finishes and colours New Age XT outer panel



Outer panel embossed stucco finish, pre-painted with similar to Ral 6005, 6009, 8017, 9016 as standard.



External side of panels with embossed wood finish, pre-painted with similar to Ral 9006, 9016 as standard.



External side of panel with smooth finish, pre-painted with similar to Ral 9006, 9016 as standard.



External side of panel pre-painted anthracite grey sandgrain finish similar to Ral 7016, structure painted with matte similar to Ral 7016.

Not all finishes are available for all models.

Internal side of panels with embossed stucco finish in white similar to RAL 9016.



External view of Stone XT sectional door, embossed stucco finish. The similar to Ral 9016 colour is standard and handle art. 62 is optional. The panel interior has an embossed stucco finish in white similar to Ral 9016.



External view of Variant XT 007/2 sectional door, embossed stucco finish. The external RAL 1014 colour and handle art. 70 are optional. The panel interior has an embossed stucco finish in white similar to Ral 9016.

### STONE XT

The Stone model of the New Age sectional doors is surprising for the elegance of its geometric design. The solution doubly advantageous: it helps to strengthen the panel and realizes a look that accents any architectural context. Two external finishes are available: embossed stucco and embossed wood. Internal side with white embossed stucco finish in white similar to Ral 9016.

### VARIANT XT

Space for imagination with Variant, the sectional door that allows you to choose the sequence of its different geometrical profiles. Two external finishes are available: embossed stucco and embossed wood. Internal side with white embossed stucco finish in white similar to Ral 9016. The layout of the various models shown is closely linked to the size of the door.

## Many colour shades



The embossed stucco, embossed wood and smooth finishes of the New Age XT sectional doors as an optional can be painted only externally in any colour on the Ballan RAL colour chart on request, for a choice of over 200 colours to choose from!

Or even in new mica-based colours: Titanium grey 5, Ballan epoxy, Graphite grey 3, Anthracite black 2, Light blue 7, Velvet green 6, similar to Corten Bal 1, Dark brown 4.

Internal side of panels with embossed stucco finish in white similar to RAL 9016.

N.B.:

The presence of slight ripples in the smooth insulated panels is to be considered normal and not a defect. It is advisable to avoid the dark coloured panels for doors exposed to the sun, since the elements may flex and limit operation of the garage door.

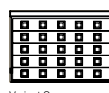

Variant Square

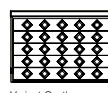

Variant Castle

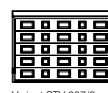

Variant STV 007/2

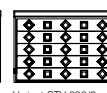

Variant STV 026/2



Variant STV 101



Variant STV 102



## New Age XT sectional doors



External view of Horizon XT sectional door, smooth finish. Panels treated externally with wood-effect super-polyester varnish light walnut colour. Handle art. 64 is optional. The panel interior has an embossed stucco finish in white similar to Ral 9016.



External view of Mixer XT sectional door, embossed wood finish. Panels treated externally with wood-effect super-polyester light walnut varnish. Handle art. 64 is optional. The panel interior has an embossed stucco finish in white similar to Ral 9016.

### HORIZON XT

Touch Horizon: it will feel like real wood. It is because externally the panels are treated with a super-polyester wood-effect varnish, which provides a faithful reproduction of the look and natural unevenness of precious wood. Unlike real wood, this material is highly weatherproof and does not require constant care and maintenance.

Available in two external surface finish versions, embossed wood and smooth. A horizontal rib in the flat panels characterizes the Horizon model.

Internal side with white embossed stucco finish in white similar to Ral 9016.



### MIXER XT

The Mixer model is characterized by a geometric design on the panels, treated externally with a super-polyester wood-effect varnish, which completely matches the look of hardwood.

Unlike real wood, this material is highly weatherproof and does not require constant care and maintenance.

Available with embossed wood external surface finish.

Internal side with white embossed stucco finish in white similar to Ral 9016.





## Wood-effect timeless elegance

The wood-effect super-polyester varnish provides a completely faithful reproduction of the appearance and unevenness of precious wood. Unlike real wood, this material is highly weatherproof and does not require constant care and maintenance.

### The finishes for the wood-effect New Age XT panel



External panel with embossed wood or smooth finish with wood-effect super-polyester varnish, available in two colours:

- Light walnut shade (frame Ral 8003)
- Dark walnut shade (frame Ral 8011).

Panel interior with embossed stucco finish in white similar to Ral 9016.

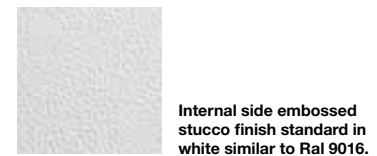

External view of the New Age Horizon sectional door with wood-effect super-polyester varnish, highlighting the side pass door with perfectly matching panelling. The side pass door, the double pane windows and handle art. 68 are optional.

N.B.:  
The presence of slight ripples in the smooth insulated panels is to be considered normal and not a defect.  
It is advisable to avoid the dark coloured panels for doors exposed to the sun, since the elements may flex and limit operation of the garage door.



## Onda sectional doors

Onda is the sectional door that lifts and slides away, leaving the space inside and outside the garage completely free. Once it is closed, it is an effective barrier to isolate the garage from temperature changes.



### Insulation: the advantage of Onda sectional doors

Onda's goal is to provide maximum thermal and acoustic comfort: a sectional door that acts as a perfect barrier to isolate the garage from temperature changes and from noise, such as that of city traffic.

Its panels are insulated with flame-retardant and totally HCFC-free polyurethane foam, to keep heat in and protect from temperature changes throughout the year.

Onda's environmental footprint complements the practicality and the strength of Ballan's sectional doors, offering an optimum closure solution even for cases where the garage door must take up as little space as possible, due to low ceilings or particularly low free headroom.



## The panel that provides strength and durability

Onda sectional doors ensure comfort due to its panels that are 40 mm thick and 500 mm high: this size has been tested to make the panel rigid and the door solid. They are composed of two facings of galvanized steel sheet with fire-retardant and HCFC-free polyurethane foam inside, which thermally insulates and soundproofs the inside of the garage.

A barrier to keep heat in and protect from temperature changes throughout the year. With the evident advantages, also from an economic point of view, that it determines.

Thanks to their "finger protection" profile and their anti-pinch hinges, they offer the best protection against accidents.

However, their safety is not only provided by the panels. In fact, Onda sectional doors are equipped with a spring break device, bear the CE marking and are accompanied by a Declaration of Performance (DoP) and by a CE Declaration of Conformity, for power-operated doors.



**Internal view of Onda sectional door (all models) showing the frame with sliding tracks, and galvanneal steel brackets.  
The chain-driven operator is optional.  
The internal side of the panels is always supplied with embossed stucco finish in white similar to Ral 9010.  
The hinges, roller brackets, and lateral profiles are painted white RAL 9010.**



**1.6**  
SM

### Onda thermal efficiency

The Onda sectional doors with standard arrangement and sizes (e.g. L 3500 x H 2500 mm) have a thermal transmittance of approximately\*:

- 1.6 W/m<sup>2</sup>K surface mounted.

(\*) The stated thermal transmittance values are to be considered guideline only, and apply to standard surface mounted up-and-over doors ranging from 8 to 10 m<sup>2</sup>. Only on request at the time of ordering, Ballan SpA will issue a thermal transmittance declaration specific to the garage door requested.



**Cable break device that engages in the event of breakage of the springs that instantly stops the door from closing.**



**Cable break device that engages in the event of cable breakage that instantly stops the door from closing (optional).**



# Onda sectional doors



External view of Onda 500 sectional door, embossed wood finish with fixed panel shaft cover. Pre-painted similar to Ral 9010 colour and galvanized steel frame are standard. The panel interior has an embossed stucco finish in white similar to Ral 9010.



External view of Onda 250 sectional door, embossed wood finish with fixed panel shaft cover. Pre-painted similar to RAL 9010 colour and galvanized steel frame are standard. The panel interior has an embossed stucco finish in white similar to Ral 9010.



External view of Onda Viva 500 sectional door, with embossed wood finish. Panels treated externally with wood-effect super-polyester varnish light walnut colour. The galvanized frame is standard. The lock with pate and aluminium handle art. 94 are optional. The panel interior has an embossed stucco finish in white similar to Ral 9010.

## ONDA 500

The Onda 500 sectional door stands out for the large slats in the insulated panel (500 mm high panels). Available in many versions: various colours of embossed wood finish, smooth, smooth polygrain and sandgrain. The panel interior is always supplied with embossed stucco finish in white similar to RAL 9010.



## ONDA 250

Onda 250 sectional door with central groove in the insulated panel (500 mm high panels). Available in many versions: various colours of embossed wood finish, smooth, smooth polygrain and sandgrain. The panel interior is always supplied with embossed stucco finish in white similar to RAL 9010.



## ONDA VIVA 500

Onda Viva 500, the sectional door insulated with 500 mm high panels, treated externally with a super-polyester wood-effect varnish, which provides a faithful reproduction of the look and natural unevenness of precious wood. Available with embossed wood finish. The panel interior is always supplied with embossed stucco finish in white similar to RAL 9010.







## External surface finishes and colours Onda panel



External side of panels with embossed wood finish, pre-painted with similar to Ral 6005, 6009, 8014, 9006, 9010.

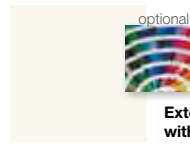

External side of panel with smooth finish, pre-painted with ivory similar to RAL 1013 as standard.

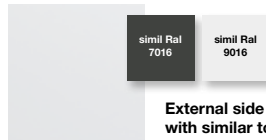

External side of panel with smooth finish, pre-painted with similar to Ral 7016, 9016.



External side of panel pre-painted anthracite grey sandgrain finish similar to Ral 7016, structure painted with matte similar to Ral 7016.



The embossed wood and smooth finishes of the Onda sectional doors as an optional can be painted only externally in any colour on the Ballan Ral colour chart on request, for a choice of over 200 colours to choose from! Or even in new mica-based colours.

Internal side of panels with embossed stucco finish in white similar to Ral 9010.

### The finishes for the wood-effect Onda panel



Wood-effect  
Light walnut  
shade

Wood-effect  
Dark walnut  
shade

External panel embossed wood finish with wood-effect super-polyester varnish  
Light walnut shade (frame Ral 8003)  
Dark walnut shade (frame Ral 8011).



Wood-effect  
Light walnut  
shade

Wood-effect  
Dark walnut  
shade

External panel smooth finish with wood-effect super-polyester varnish  
Light walnut shade (frame Ral 8003)  
Dark walnut shade (frame Ral 8011).



Internal side embossed stucco finish in white similar to Ral 9010.

Not all finishes are available for all models.

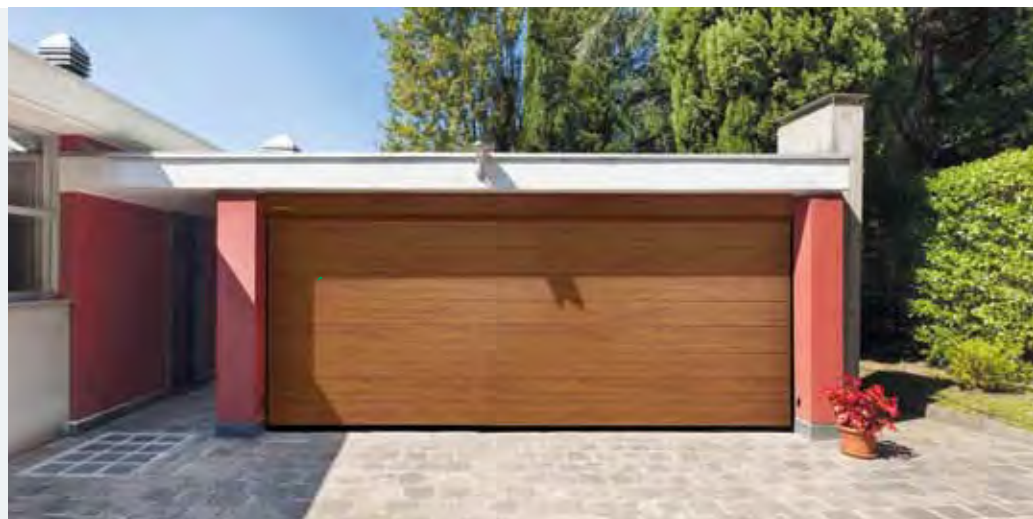

External view of Onda Viva 250 sectional door, with smooth finish. Panels treated externally with a super-polyester wood-effect varnish light walnut colour. The galvanised frame is standard. The lock with pate and aluminium handle art. 94 are optional. The panel interior has an embossed stucco finish in white similar to Ral 9010.

## ONDA VIVA 250

Onda Viva 250, the sectional door insulated with 500 mm high panels externally treated with a super-polyester wood-effect varnish, which provides a faithful reproduction of the look and natural unevenness of precious wood. The model has a central groove in the panel. Available with smooth surface finish. The panel interior is always supplied with embossed stucco finish in white similar to RAL 9010.

## Wood-effect timeless elegance

The wood-effect super-polyester varnish provides a completely faithful reproduction of the appearance and unevenness of precious wood. Unlike real wood, this material is highly weatherproof and does not require constant care and maintenance.

N.B.:  
The presence of slight ripples in the smooth insulated panels is to be considered normal and not a defect. It is advisable to avoid the dark coloured panels for doors exposed to the sun, since the elements may flex and limit operation of the garage door.



## Onda sectional doors : optional

### The convenience of a door in the door

The pass door is made with grey anodized aluminium profiles and is equipped with concealed hinges and a satin chrome finish handle. Supplied with overhead door closer mechanism and always mounted at the centre for RH or LH pull-type opening (external view). On request, the anodized aluminium profiles can be painted with a RAL colour. The internal hinges are always white.



Detail of the overhead door closer mechanism of the pass door (inside view).



Detail of the concealed hinges of the pass door (inside view).

## The shaped shaft cover

The shaft with springs, which controls the door's operation, can optionally be protected by a specially shaped cover that helps prevent accidents and improves its looks.



**Internal view of Onda sectional door, with central pass door (optional).**  
The pass door is made with grey anodized aluminium profiles, on request they can be painted with a RAL colour.  
The hinges are made of steel and painted with white similar to RAL 9010.  
The chain-driven operator is optional.

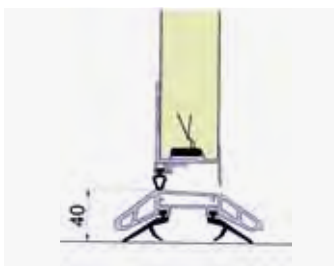

**Detail of the lower anodized aluminium profile with lowered threshold (40 mm above the floor).**  
Lowered thresholds can be fitted to sectional doors up to 3800 wide and 3000 mm high.



## Sectional doors : optional



### Fixed windows

frame painted the same colour

The rectangular windows with small frames are painted the same colour of the outer panelling.

The tempered and anti-explosion glass is 380 x 190 mm, and is available with different types of glazing.

- Art. 310 - Double pane frosted window, with transparent decoration.**
- Art. 320 - Double pane frosted window, with transparent decoration.**
- Art. 330 - Clear double pane window.**
- Art. 370 - Totally frosted double pane window.**
- Art. 340 - Blue Stopsol double pane window.**
- Art. 350 - Blue Stopsol bevelled double pane window.**
- Art. 360 - Clear engraved double pane window.**
- Art. 380 - Clear acrylic window.**
- Art. 390 - Clear blue acrylic window.**

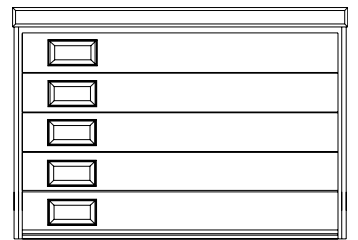
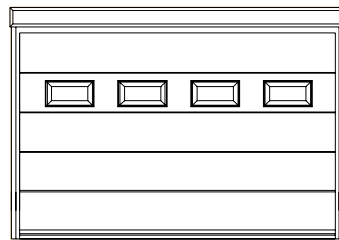

### Fixed windows

with stainless steel frame

Rectangular windows with polished stainless steel frames.

The tempered and anti-explosion glass is 380 x 190 mm, and is available with different types of glazing.

- Art. 310X - Double pane frosted window, with transparent decoration.**
- Art. 320X - Double pane frosted window, with transparent decoration.**
- Art. 330X - Clear double pane window.**
- Art. 370X - Totally frosted double pane window.**
- Art. 340X - Blue Stopsol double pane window.**
- Art. 350X - Blue Stopsol bevelled double pane window.**
- Art. 360X - Clear engraved double pane window.**
- Art. 380X - Clear acrylic window.**
- Art. 390X - Clear blue acrylic window.**

Fixed window provide better interior garage lighting and fit perfectly with the look of the door

Fixed window frame in Alunox and PMMA glass

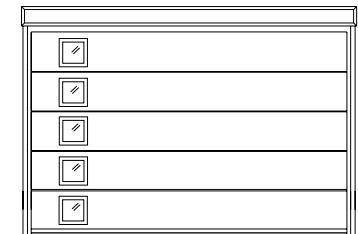
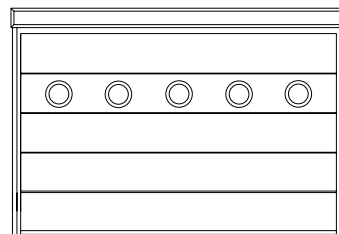

Many positions in the panels are possible for windows.

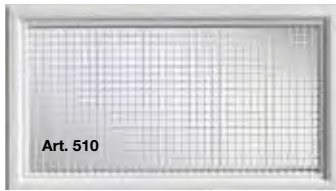
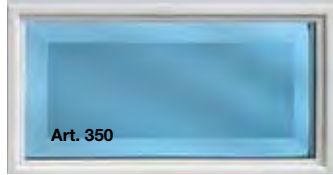
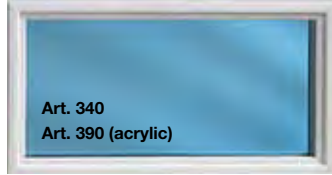
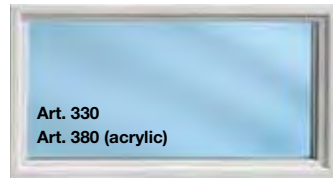

Screened or louvred window (380 x 190 mm) with outer frame painted same colour as outer panelling.

Art. 510 - Screened window with perforated 8x8 mm square wire mesh.

Provides 0.05 m<sup>2</sup> of ventilation.

Art. 520 - Louvred window with galvanized steel profiles.

Provides 0.03 m<sup>2</sup> of ventilation.

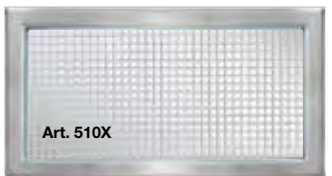
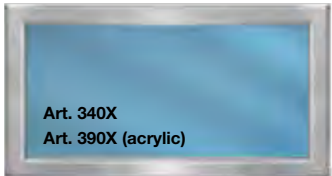
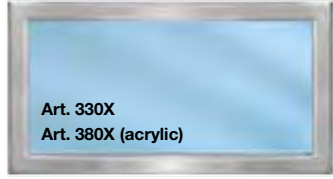
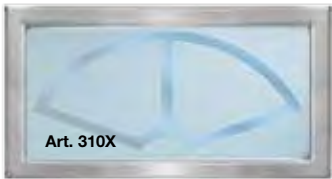

Screened or louvred window (380 x 190 mm) with polished stainless steel frames.

Art. 510X - Screened window with perforated 8x8 mm square wire mesh.

Provides 0.05 m<sup>2</sup> of ventilation.

Art. 520X - Louvred window with galvanized steel profiles.

Provides 0.03 m<sup>2</sup> of ventilation.



## Vinyl window frame



Fixed window frame in Alunox and PMMA glass, square 260x260 mm or round diameter 260 mm.

Acrylic window, also available burglar-proof, 548 x 248 mm, 548 x 141, or 548 x 84 mm with black or white vinyl frame.



# Sectional doors : optional



Art. 62



Art. 64



Art. 68



Art. 70



Art. 98



Art. 94



Plate and martellina-type handle.

## The multifunction catch-proof handle

The multifunction handle is concealed in the panel (catch-proof) and contains the lock, the bolt and a wide bidirectional grip. The lock's protection cover is made of high thickness brass to ensure excellent break-in resistance. Inside, the (anti-panic) fixed key makes it easy to open the door if needed in an emergency.

Optional for New Age and Onda models.

- Art. 62 - Brass handle with polished finish.**
- Art. 64 - Brass handle with bronze finish.**
- Art. 68 - ABS handle with brass inside.**
- Art. 70 - Brass handle with satin chrome finish.**



Internal view



The multifunction handle is patented by Ballan.

## Aluminium handle

Aluminium handle with satin brass finish art. 94, or with satin chrome finish art. 98, always with lock with European cylinder. On request also with drill-proof Defender safety cylinder (also mounted in the lock of the pass door, if provided).

Optional for Onda models.

- Art. 94 - Aluminium plate and handle with satin brass finish.**
- Art. 98 - Aluminium plate and handle with satin chrome finish.**

## ABS handle

Black ABS plate and martellina-type handle includes shaped cylinder.

Optional for Onda models.



## Sectional doors : safety



The Declaration of Performance is one of the most innovative aspects of the Regulation 305/2011.



Declaration of Performance (DoP), which describes the characteristics of the product in compliance with CPR 305/2011.



CE Declaration of Conformity, which certifies the respect of all European standards in force for power-operated doors.



Installation, Use and Maintenance Handbook: an easy-to-consult guide that provides all the necessary information.



## Garage safety pursuant to CPR 305/2011 and EN 13241-1 Product Standard

### Manual sectional doors:

The sectional door is built in accordance with all the mechanical requirements and additional performance requirements specified by the Product Standard. Therefore it requires:

- spring break device to prevent the door leaf from dropping accidentally,
  - anti-pinch joint between the panels.
- They bear the CE marking and come with a Declaration of Performance (DoP).

### Manual sectional doors: (ready for operator fitting)

(not available for Onda model)

The sectional door is built in accordance with all the mechanical requirements and additional performance requirements specified by the Product Standard. Therefore it requires:

- spring break device to prevent the door leaf from dropping accidentally,
- anti-pinch joint between the panels,
- cable winder drum guard,
- protection of the sliding rollers with vinyl shells.

They bear the CE marking and come with a Declaration of Performance (DoP).

The door is designed so that (subsequent) addition of an operator respects all the mechanical requirements specified by the Product Standard, enabling the installer to issue a CE Declaration of Conformity (mandatory). Ballan offers two different trim levels for this version:

- retrofit provision for NA operators (complete with vinyl shells for rollers sliding in tracks and two cable winder drum guards),
- retrofit provision for NA-T chain-driven operators (complete with vinyl shells for sliding rollers in tracks, two cable winder drum guards and motor arm fixing bracket).

### Sectional doors with operator:

The sectional door is built in accordance with all the mechanical requirements, the automatic operation and the additional mandatory features required by the Product Standard. Therefore it requires:

- spring break device to prevent the door leaf from dropping accidentally,
- anti-pinch joint between the panels,
- cable winder drum guard,
- guards for sliding rollers with vinyl shells,
- motors equipped with force limiter device.

They bear the CE marking and come with a Declaration of Performance (DoP) and CE Declaration of Conformity.



## Thanks to our operators, sectional doors are at your command

Several ceiling-mounted operators with chain transmission are available for Ballan sectional doors.

The operators are made up of a 24 V direct current irreversible mechanical gearmotor with control panel, incorporated lamp and manual operating system to be used in case of a fault or electric blackout. Chain-driven ceiling-mounted operators, become a lock due to their irreversible motors.

They are anti-crushing by virtue of the greater sensitivity of the motor and have an incorporated electronic control unit that checks the safety devices during each operation and can be interfaced for maintenance management and for reprogramming if needed.



- Operator accessories**
1. Motor.
  2. External manual unlocking device
  3. Internal button.
  4. Code keypad.
  5. Movement indicator flashing light.
  6. Remote control.
  7. Pair of photocells (for wall mounting).



CE marking product identification data plate stating all the data required by current regulations.



Cable break device that engages in the event of cable breakage that instantly stops the door from closing (optional).



Cable break device that engages in the event of breakage of the springs that instantly stops the door operation (mandatory).



Presence detectors, applied on the side jambs, instantly block door operation in the event of transit of persons or objects (optional).



# Sectional doors: technical specifications

## New Age XT sectional doors

### HORIZONTAL SECTION

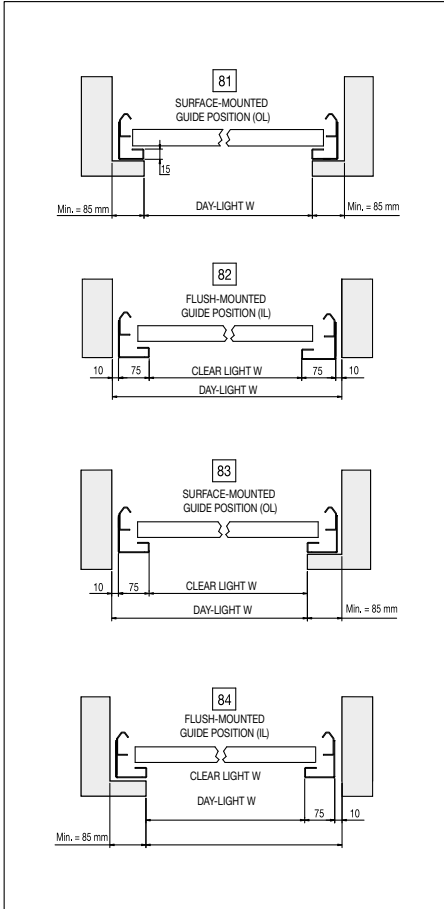

### STANDARD SLIDING - VERTICAL SECTION

#### AUTOMATIC OPERATION

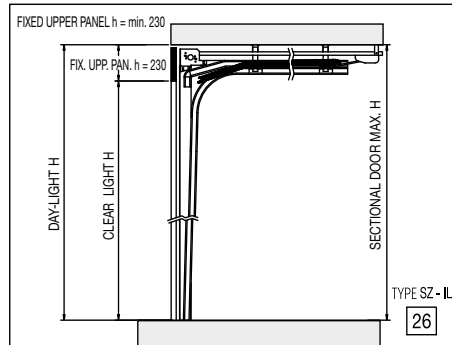

#### MANUAL OPERATION

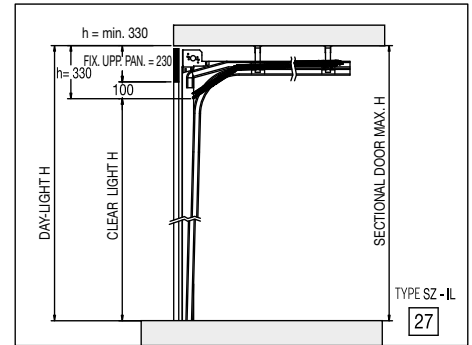

#### AUTOMATIC OPERATION

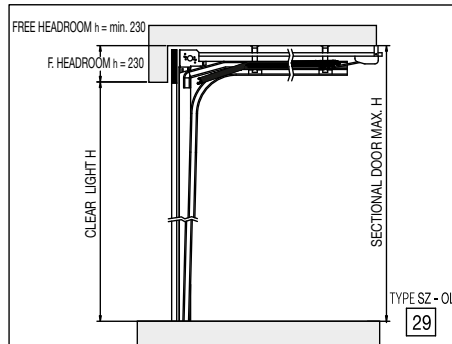

#### MANUAL OPERATION

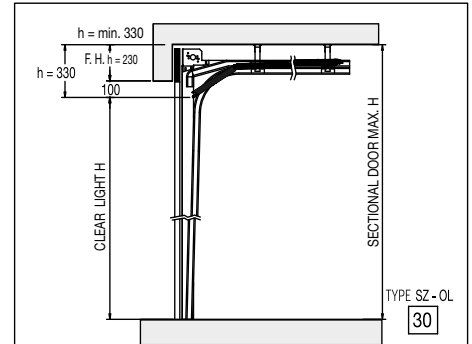

### STANDARD SLIDING WITH HORIZONTAL GUIDES INCLINED AT \* DEGREES - VERTICAL SECTION

#### MANUAL AND AUTOMATIC OPERATION

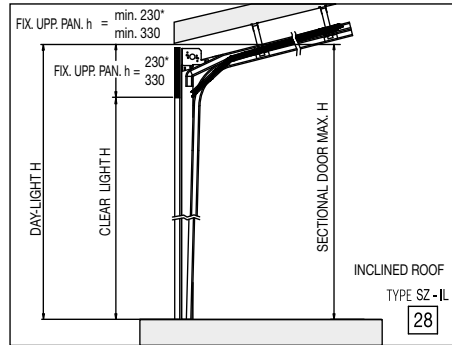

#### MANUAL AND AUTOMATIC OPERATION

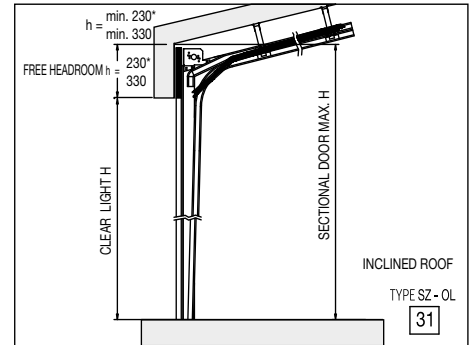

N.B. : Maximum feasible angle 24° equal to a gradient of 45%.

\* Up to max. angle 13° min. fixed upper panel dimensions 230 mm  
From angle of 13° min. fixed upper panel dimensions 330 mm

### MEASUREMENTS TO BE TAKEN

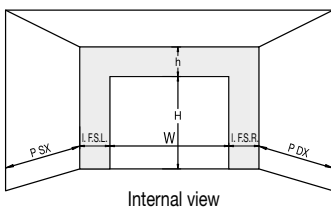

Key:  
I = free sideroom  
P = free depth space  
h = free headroom

	MANUAL OPERATION	AUTOMATIC OPERATION
I	FREE SIDEROOM min. 85 mm	min. 85 mm
P	FR. DEPTH SPACE min. = H + 300 mm	min. = H + 800 mm
h	FR. HEADROOM min. 330 mm	min. 230 mm

### STANDARD SLIDING FOR UPPER BEAM AT 230 MM - VERTICAL SECTION

#### MANUAL AND AUTOMATIC OPERATION

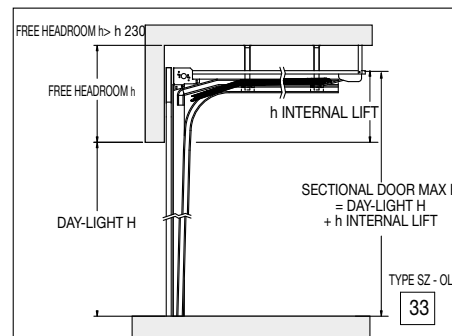

N.B.: with internal lift > 450 mm the tracks will be reinforced with tubular (pay attention to the floor threshold).

# Onda sectional doors

## HORIZONTAL SECTION

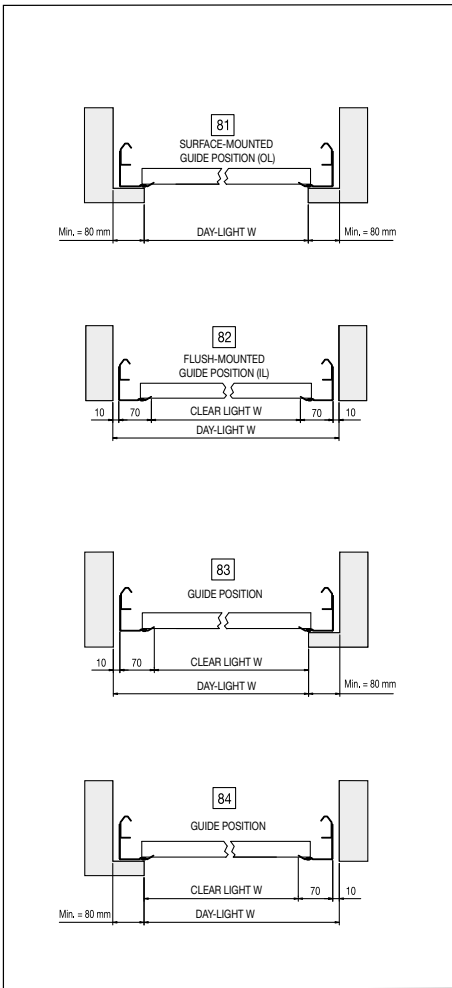

## STANDARD SLIDING - VERTICAL SECTION

AUTOMATIC OPERATION

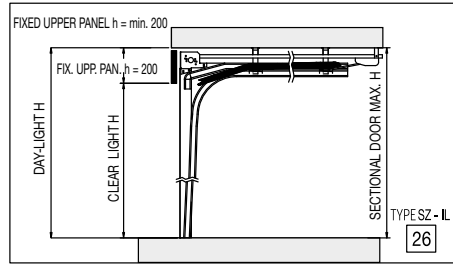

MANUAL OPERATION

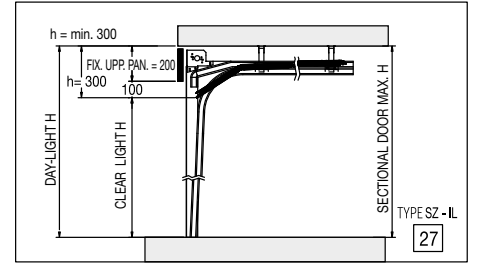

AUTOMATIC OPERATION

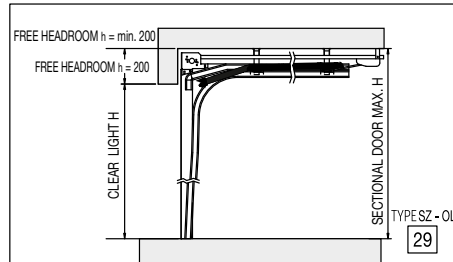

MANUAL OPERATION

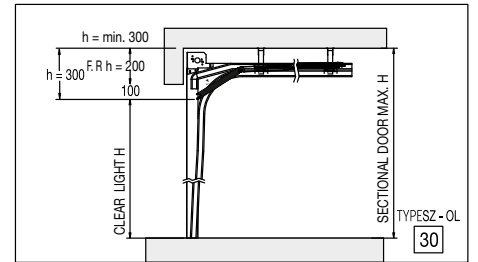

## STANDARD SLIDING WITH HORIZONTAL GUIDES INCLINED AT \* DEGREES - VERTICAL SECTION

MANUAL AND AUTOMATIC OPERATION

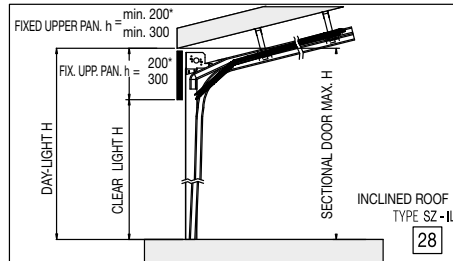

MANUAL AND AUTOMATIC OPERATION

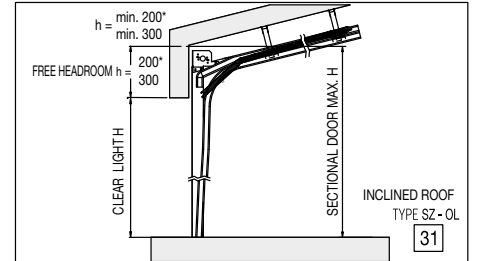

\* Up to max. angle 13° min. fixed upper panel dimensions 200 mm  
From angle of 13° min. fixed upper panel dimensions 300 mm.

## STANDARD SLIDING FOR UPPER BEAM AT 230 MM - VERTICAL SECTION

MANUAL AND AUTOMATIC OPERATION

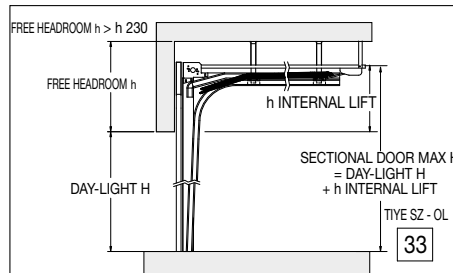

N.B.:  
with internal lift > 450 mm the tracks will be reinforced with tubular (pay attention to the floor threshold).

## MEASUREMENTS TO BE TAKEN

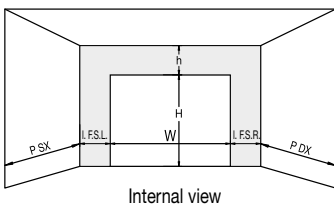

Key:  
I = free sideroom  
P = free depth space  
h = free headroom

	MANUAL OPERATION	AUTOMATIC OPERATION
I	FREE SIDEROOM min. 80 mm	min. 80 mm
P	FR. DEPTH SPACE min. = H + 300 mm	min. = H + 800 mm
h	FR. HEADROOM min. 300 mm	min. 200 mm

## PARTIALLY VERTICAL SLIDING

MANUAL AND AUTOMATIC OPERATION

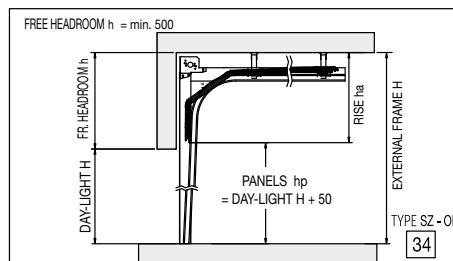

## MANUAL AND AUTOMATIC OPERATION

MANUAL AND AUTOMATIC OPERATION

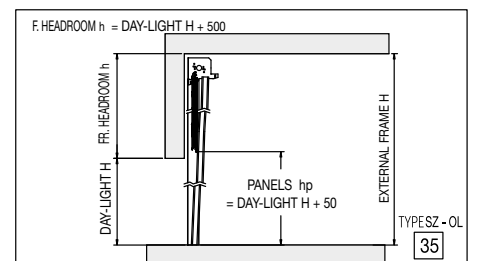



# Flexa lateral sliding doors



External view of Flexa 500 lateral sliding door, embossed wood finish. The similar to RAL 9010 colour and black ABS handle are standard. The panel interior has an embossed stucco finish in white similar to Ral 9010.



External view of Flexa 250 lateral sliding door, embossed wood finish. The similar to RAL 9010 colour and black ABS handle are standard. The panel interior has an embossed stucco finish in white similar to Ral 9010.

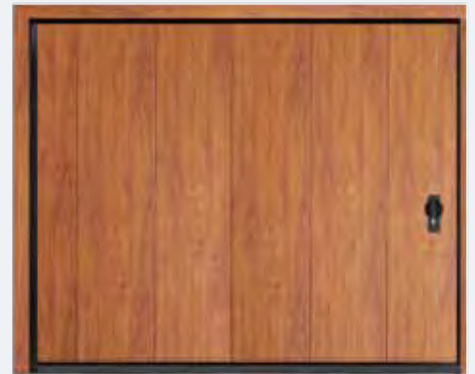

External view of Flexa Viva 500 lateral sliding door, embossed wood finish, with embossed wood finish. Panels treated externally with wood-effect super-polyester varnish light walnut colour. The similar to Ral 9010 colour and black ABS handle are standard.

## FLEXA 500

The Flexa 250 lateral sliding door with insulated panel (L 500 mm panels). Available in many versions: various colours of embossed wood finish, smooth, smooth polygrain and sandgrain. The panel interior is always supplied with embossed stucco finish in white similar to Ral 9010.



## FLEXA 250

The Flexa 250 lateral sliding door with a central groove in the insulated panel (L 500 mm panels). Available in many versions: various colours of embossed wood finish, smooth, smooth polygrain and sandgrain. The panel interior is always supplied with embossed stucco finish in white similar to Ral 9010.



## FLEXA VIVA 500

The Flexa Viva 500 lateral sliding door with insulated panel (L 500 mm panels). Treated externally with a super-polyester wood-effect varnish, which provides a faithful reproduction of the look and natural unevenness of precious wood. Available with embossed wood finish. The panel interior is always supplied with embossed stucco finish in white similar to Ral 9010.



## Is the garage ceiling too low?

The solution is the Flexa lateral sliding door, an exclusive Ballan design, that moves smoothly and quietly, and can be installed even in small spaces.



An exclusive Ballan design, the new Flexa is the lateral sliding door which allows a suitable closure even in difficult situations. This classic garage closure is popular for its convenience... because it can be partially opened at full height to allow people or things to pass, such as bicycles or motorcycles.

## External surface finishes and colours Flexa panel



External side of panels with embossed wood finish, pre-painted with similar to Ral 6005, 6009, 8014, 9006, 9010.

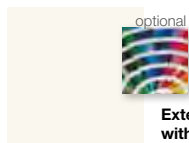

External side of panel with smooth finish, pre-painted with ivory similar to RAL 1013 as standard.



External side of panel with smooth finish, pre-painted with similar to Ral 7016, 9016.



External side of panel pre-painted anthracite grey sandgrain finish similar to Ral 7016, structure painted with matte similar to Ral 7016.



The embossed wood and smooth finishes of the Flexa sectional doors as an optional can be painted only externally in any colour on the Ballan Ral colour chart on request, for a choice of over 200 colours to choose from! Or even in new mica-based colours.

Internal side of panels with embossed stucco finish in white similar to Ral 9010.

## The finishes for the wood-effect Onda panel

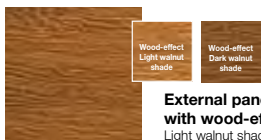

External panel embossed wood finish with wood-effect super-polyester varnish  
Light walnut shade (frame Ral 8003)  
Dark walnut shade (frame Ral 8011).

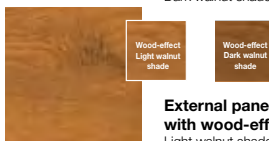

External panel smooth finish with wood-effect super-polyester varnish  
Light walnut shade (frame Ral 8003)  
Dark walnut shade (frame Ral 8011).



Internal side embossed stucco finish in white similar to Ral 9010.

Not all finishes are available for all models.

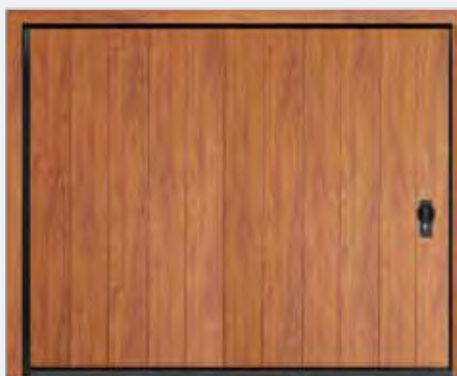

External view of Flexa Viva 250 lateral sliding door, embossed wood finish, with embossed wood finish. Panels treated externally with wood-effect super-polyester varnish light walnut colour. The similar to Ral 9010 colour and black ABS handle are standard.



## FLEXA VIVA 250

The Flexa Viva 250 lateral sliding door with a central groove in the insulated panel (L 500 mm panels). Externally treated with a super-polyester wood-effect varnish, which provides a faithful reproduction of the look and natural unevenness of precious wood. The model has a central groove in the panel. Available with smooth surface finish. The panel interior is always supplied with embossed stucco finish in white similar to Ral 9010.

## More light or air for the garage

As an option, there are several 380 x 190 mm windows made of tempered and burglar-proof glass, with small frames and painted with RAL colours, or made of stainless steel. The glass can be selected with different solutions frosting effects, also with ventilation.

Black or white vinyl frames are also available in different sizes.

N.B.:

The presence of slight ripples in the smooth insulated panels is to be considered normal and not a defect. It is advisable to avoid the dark coloured panels for doors exposed to the sun, since the elements may flex and limit operation of the garage door.





## Flexa lateral sliding doors

### New Flexa designed and built exclusively by Ballan

The Flexa door is made up of the perimetral structure, the lower, load-bearing track made of galvanized steel and the upper track made of galvanized steel painted similar to RAL 9016. The 40 mm thick and 500 mm wide insulated panels are composed of two facings of galvanized steel sheet with flame-retardant and HCFC-free polyurethane foam inside, which thermally insulate and soundproof the inside of the garage.

They are available in different finishes, including wood-effect, matchable to existing shutters or sectional doors. Various windows can be fitted in the panels to increase the light and/or ventilation of the garage. Available manual or power-operated.

### Compliant with Safety standards

The safety of the Flexa door is guaranteed by its CE Marking, by a Declaration of Performance (DoP) and by a CE Declaration of Conformity, for power-operated doors.

Sizes available:  
from 2000 to 6000 mm long  
from 1800 to 3000 mm high.



The lower track requires no maintenance, and is in fact a barrier to dust, dirt and water.



#### 1 Easy and accurate running on the floor.

Thanks to the galvanized steel floor track with a footprint of just 17 mm it is no obstacle to passage ensures a safe and quiet movement. The floor-mounted omega track does not need to be cleaned as normal channel or recessed floor tracks. The upper track maintains sliding stable and prevents the panels from rocking.

#### 2 Perimetral structure.

The perimeter structure and the upper tracks are made of galvanized steel profiles painted similar to RAL 9016, and are supplied pre-assembled, complete with junction brackets for quick and easy installation.

#### 3 Seals.

The Flexa sliding door is equipped with rubber gaskets mounted along the entire perimeter of the structure.

#### 4 With floor-mounted double flexible seal (external and internal), that are designed to adapt to any kind of floor.

#### 5 ABS handle.

The door can also be easily operated by hand, using the comfortable and strong ABS handle, to open it only far enough to enter or exit the garage more quickly. Depending on the application, the black ABS handle may look different.

### Covers kit

C-shaped covers for the peripheral structure are available, made of galvanized steel and painted in the same colour as the panels.

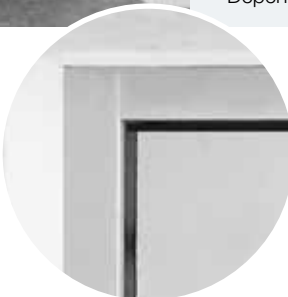

1.8  
SM

#### Flexa thermal efficiency

The Flexa lateral sliding doors with standard arrangement and sizes (e.g. L 4500 x H 2500 mm) have a thermal transmittance of approximately\*:

- 1.8 W/m<sup>2</sup>K surface mounted.



(\*) The stated thermal transmittance values are to be considered guideline only, and apply to standard surface mounted up-and-over doors ranging from 8 to 10 m<sup>2</sup>. Only on request at the time of ordering, Ballan SpA will issue a thermal transmittance declaration specific to the garage door requested.

Simple and fast door installation thanks to pre-assembled track groups.



**6 Protective cover.**

All the sliding wheels are protected by a white ABS shaped cover that ensures safety and proper operation when in motion.

**7 Lower curve unit.**

The single radius and variable angle side curve, made of galvanized steel, provides anti-pinch safety between the panels and is shaped so as to provide ensure smooth running.

**8 Operator.**

Operator installation can adapt to the application depending on the space available in the garage. The motor can be front, side or wall mounted. Various accessories are available, such as remote controls, photocells, flashing lights, etc.

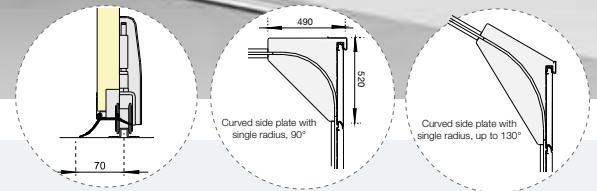

Technical drawings

**LH closing (internal view)**

Horizontal section

Standard sliding

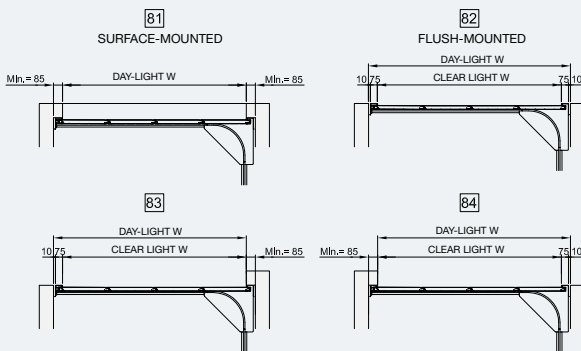

Vertical section  
Front

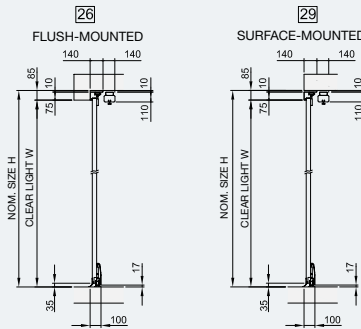

Side  
with ceiling-mounted motor

with wall-mounted side motor

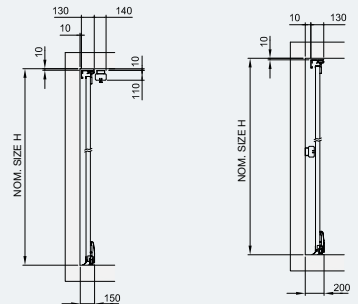

Sliding at degrees > 90 up to 130 °

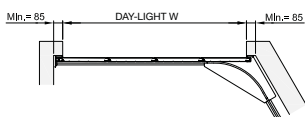

Sliding scrolling

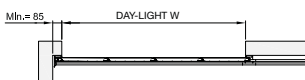

**Ballan SpA reserves the right to apply modifications to products without notice.**

The RAL colours and shades of wood shown in this printed media are to be considered guideline only. The photos with product settings are solely for the purpose of illustrating the model and are guideline only. All texts, illustrations and photos are the exclusive property of Ballan SpA: any unauthorised total or partial reproduction is strictly prohibited.

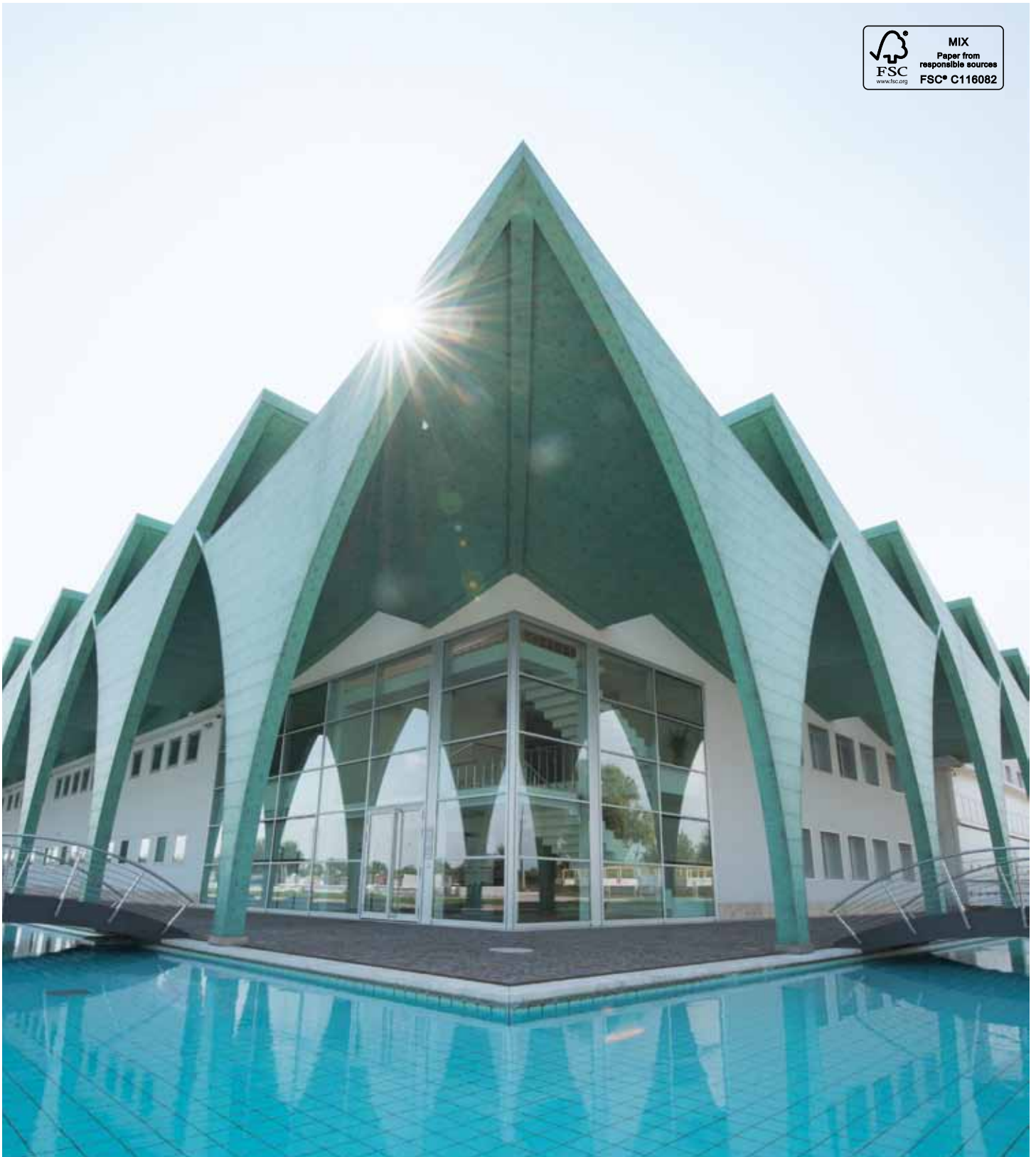

Paid-up Share Capital Euro 5,000,000  
Register of Companies, PD / Tax code /  
VAT Reg. 00327010286  
REA PD 0118254



Certified quality management system

### Ballan SpA

Via Restello 98  
35010 Villa del Conte (PD) Italy  
Tel. + 39 **049 9328111**  
Fax + 39 049 9325311  
e-mail: [ballan@ballan.com](mailto:ballan@ballan.com)  
[www.ballan.com](http://www.ballan.com)

